

TAFELN

TAFEL 1

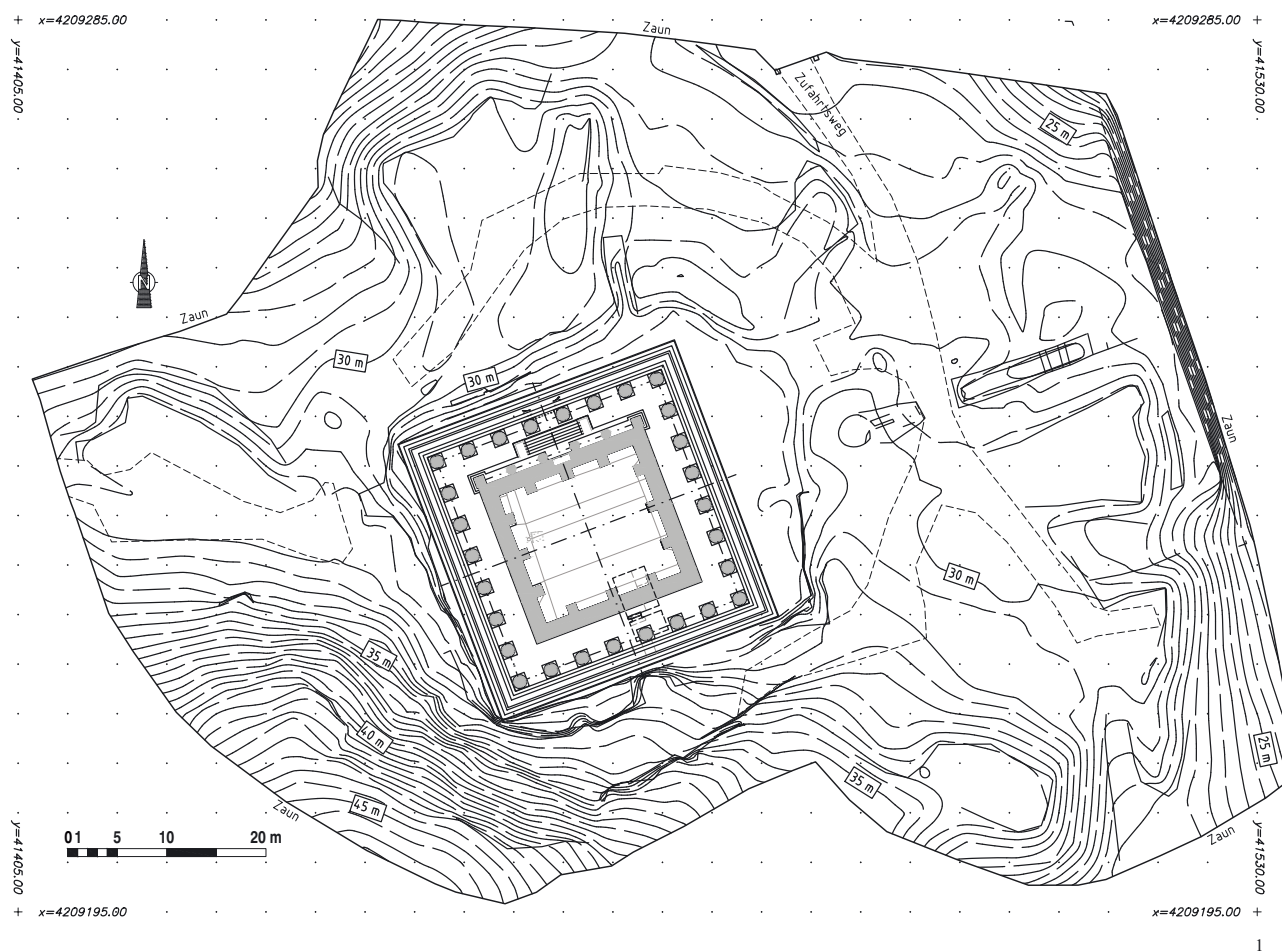

2



3

- 1: Lageplan. M = 1 : 500, genordet, Mausoleum mit eingezäuntem Grundstück;
 2: Das Mausoleum vom Talgrund von Osten aus gesehen, davor die Terrassenmauer, dahinter der Tumulus, rechts der neue Autobahndamm, im Hintergrund auf der mittleren Bergkuppe die Burg »Keci-Kalesi«;
 3: Das Mausoleum vom Tumulus aus gesehen.

TAFEL 2



1



2

1: Nordansicht. 2: Westansicht.



1



2

1: Ostansicht, im Hintergrund der Tumulus;
2: Südostansicht, im Hintergrund die Autobahntrasse und das Kaystrostal.

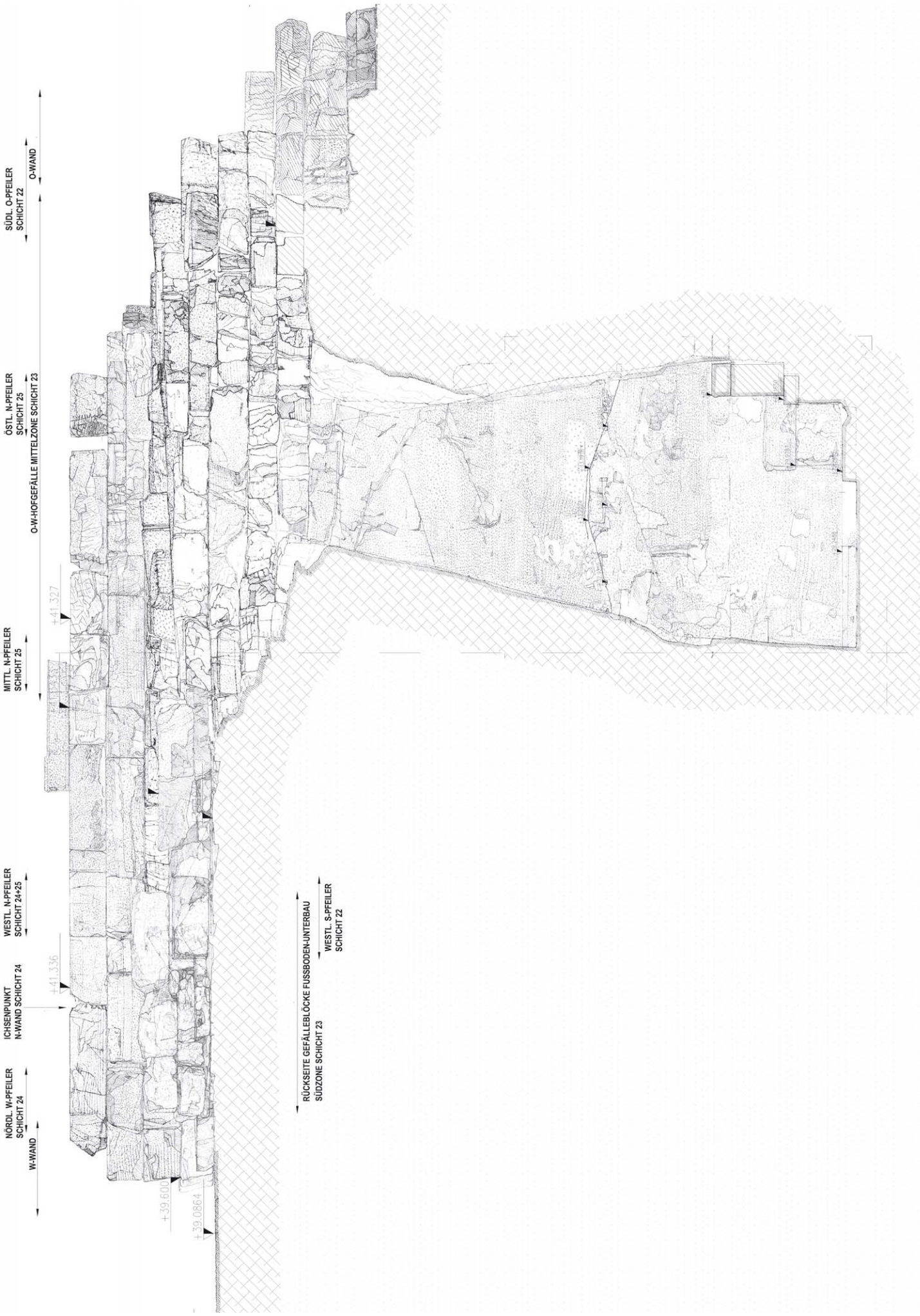

N-WAND OG SCHICHT 22-26
 N-PFEILER SCHICHT 24o+25
 N-ZONE HOFGEFÄLLE
 MITTELZONE HOFGEFÄLLE
 ANSCHLUSSKANTE ZUM MITTELPFEILER DER OSTWAND

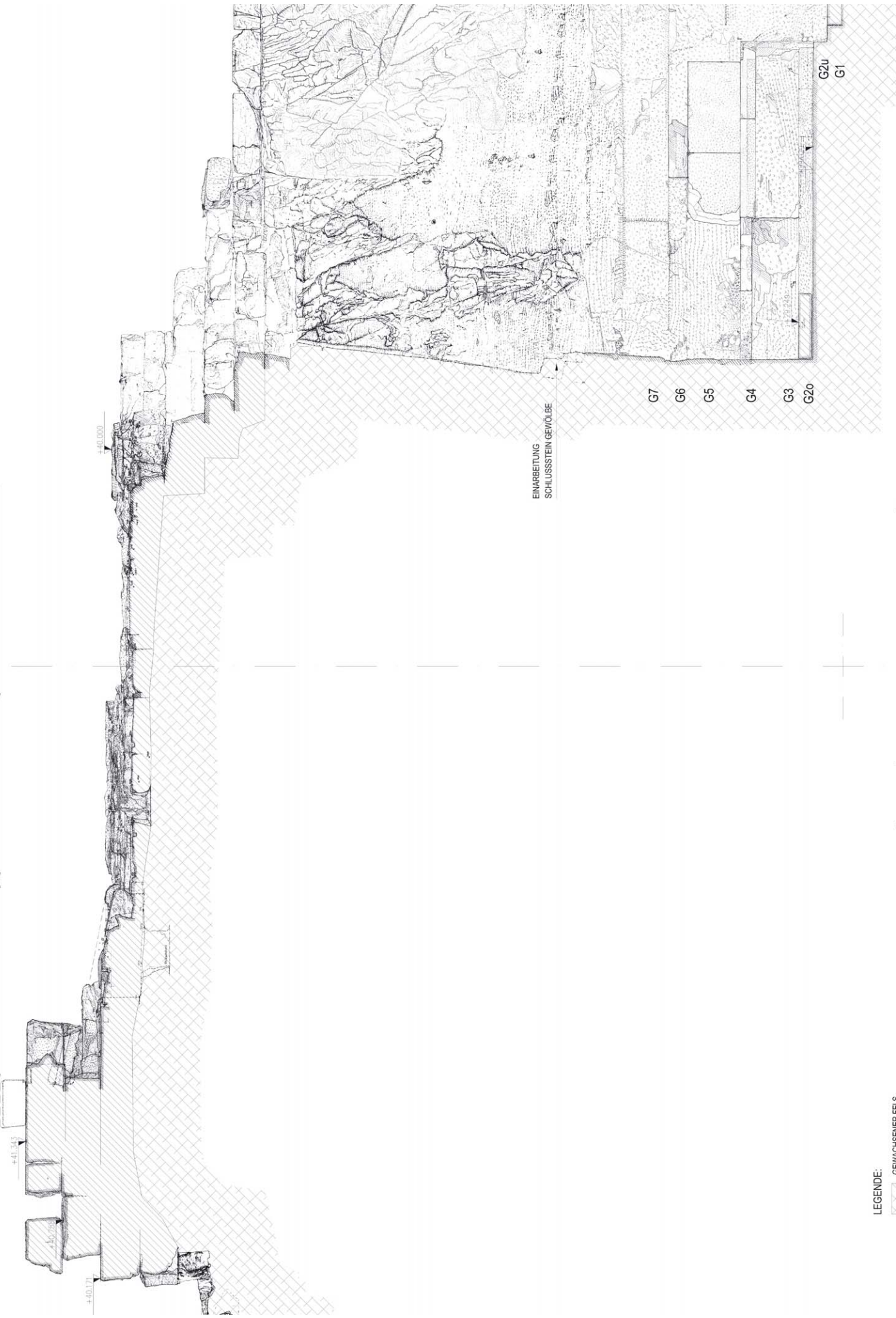

LEGENDE:

-  GEWACHSENER FELS
-  BLOCHE DER MARMORVERKLEIDUNG UND DER ÜBERBAUUNG



FELSPLATEAU UNTER
CA. AU

W-WAND

ERHALTENE MAUERRESTE DER NÖRDLICHEN HOFWAND SCHICHT 22-26

ÖSTL. N-PELLER
SCHICHT 25

O-WANDKANTE IM FUSSBODENUNTERBAU
UND N-WAND-FUNDAMENT SCHICHT 23

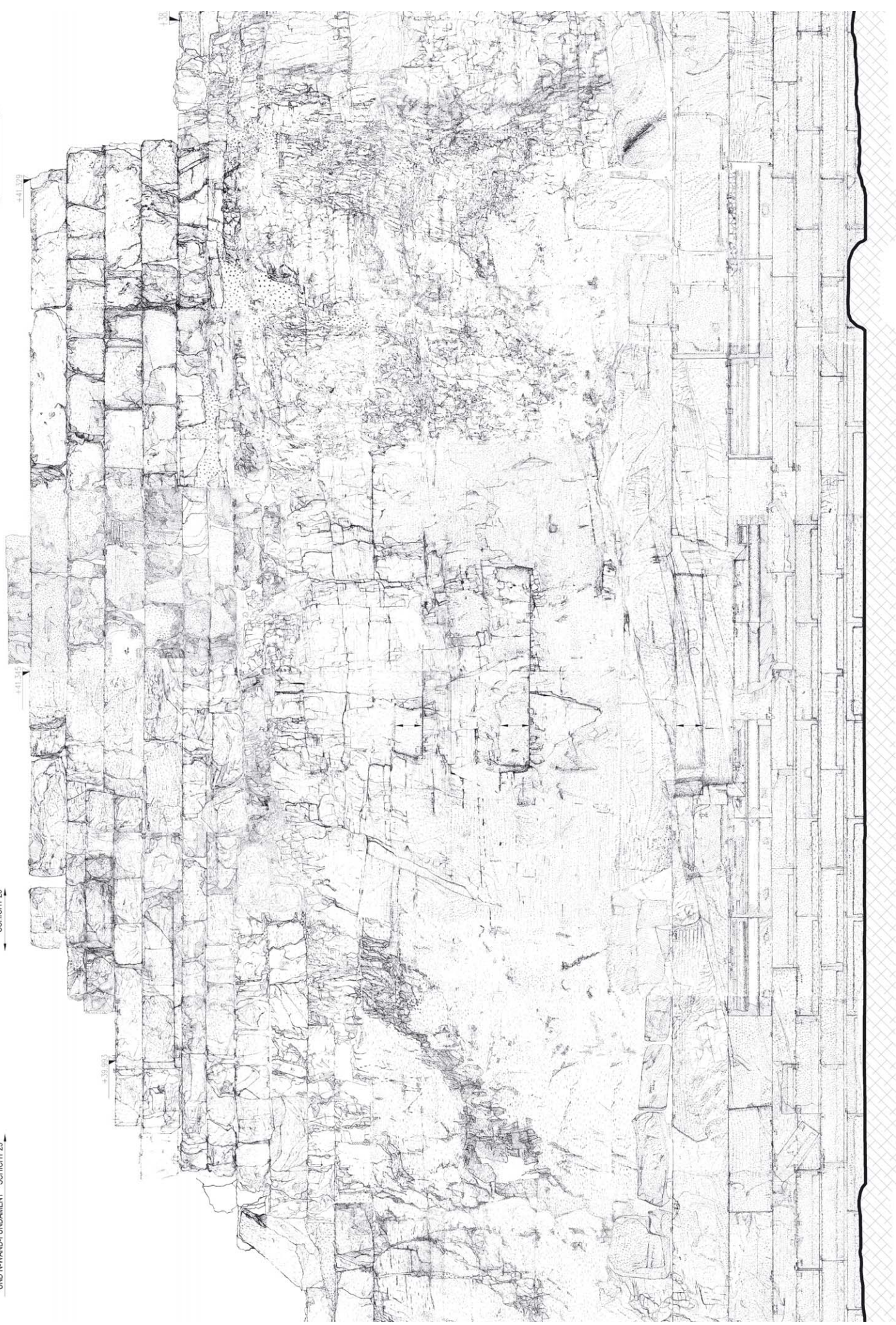

FELSWAND-EINARBEITUNGEN FÜR SCHEINTÜR
HÖHE CA. SCHICHT 6 - 11 - 14

SCHWATZE IN DER FELS-
STUFUNG HÖHE SCHICHT 5



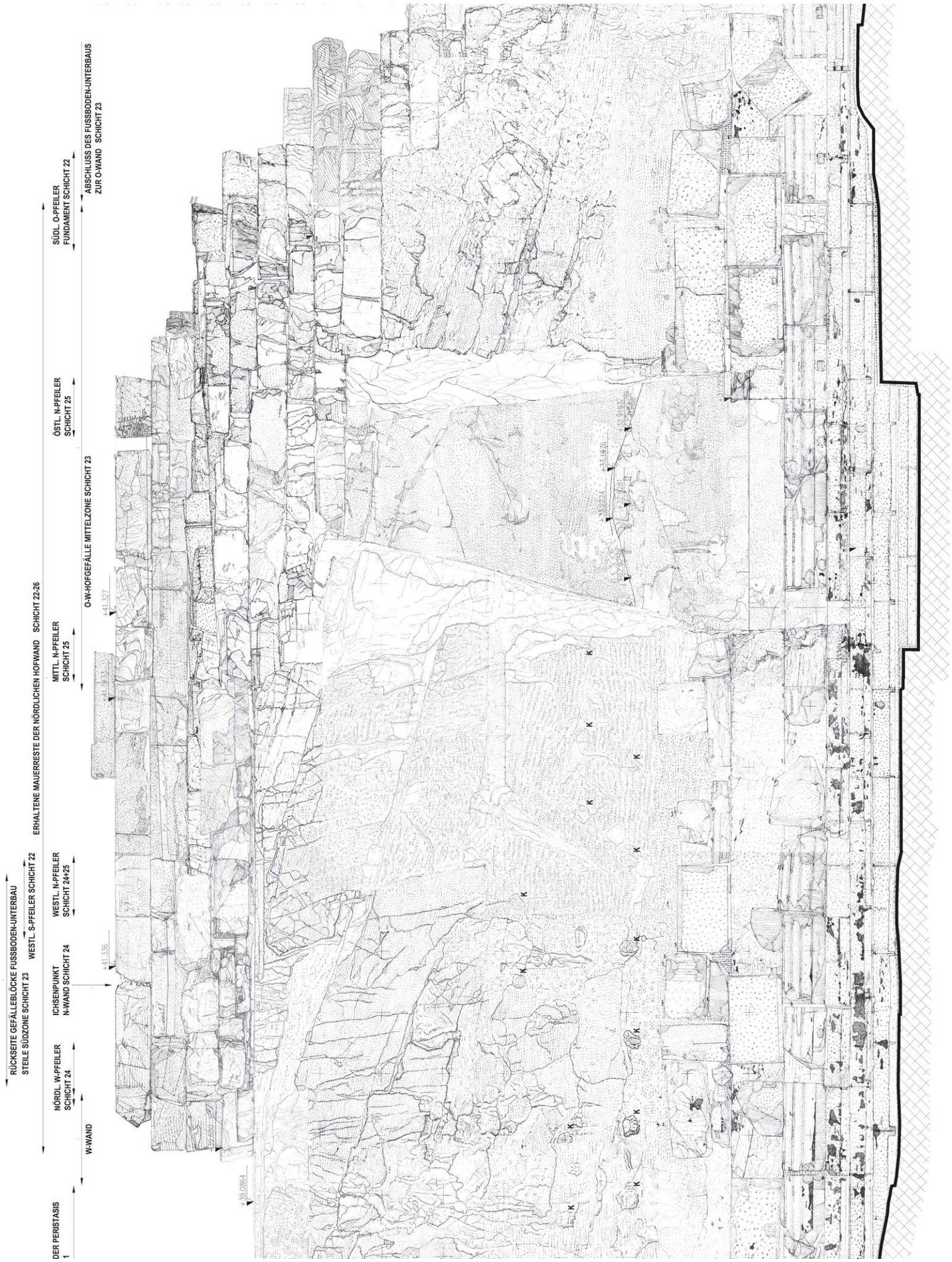

TAFEL 8

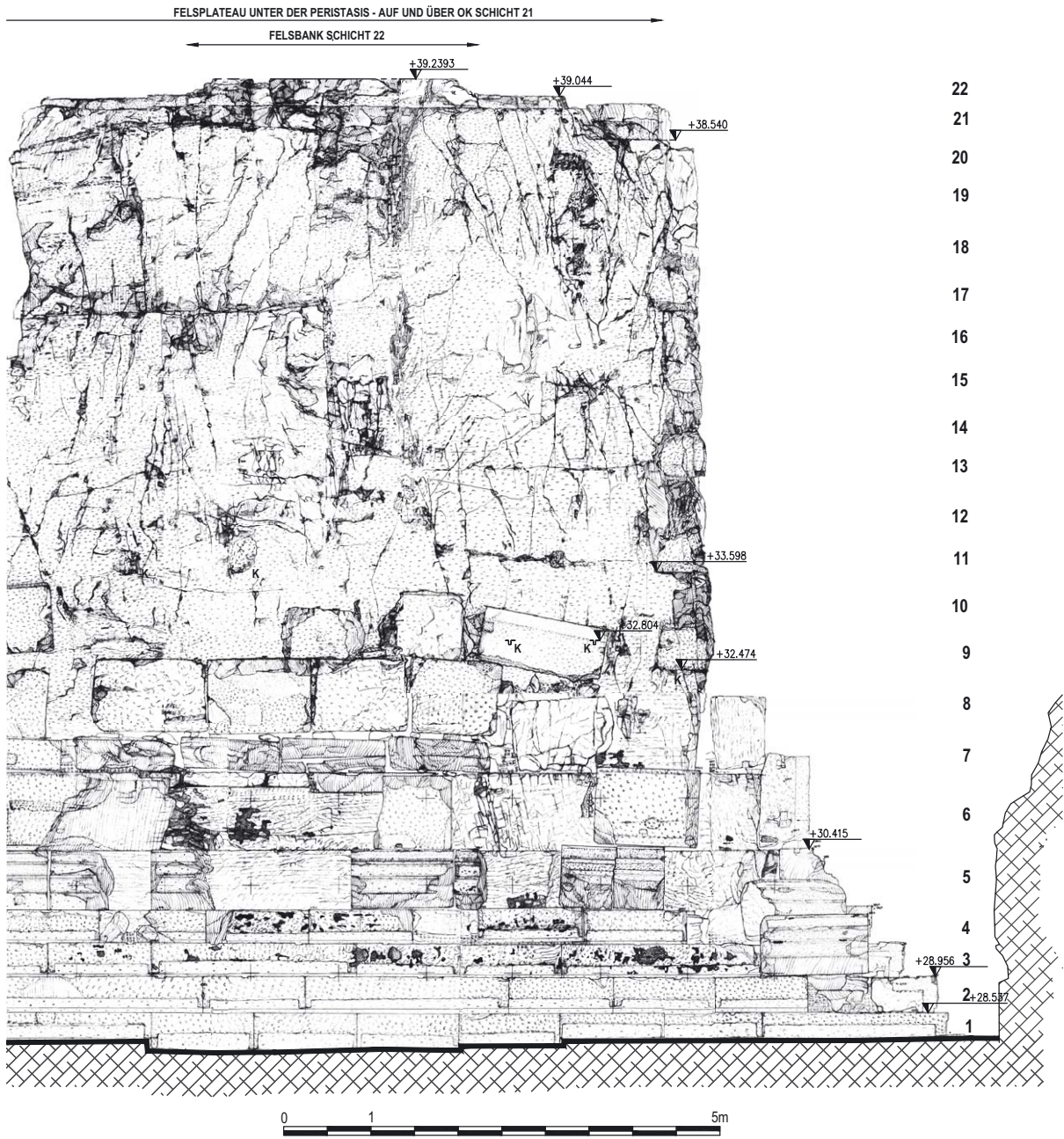

Südteil der Westfassade. Bestandsplan M = 1 : 50.

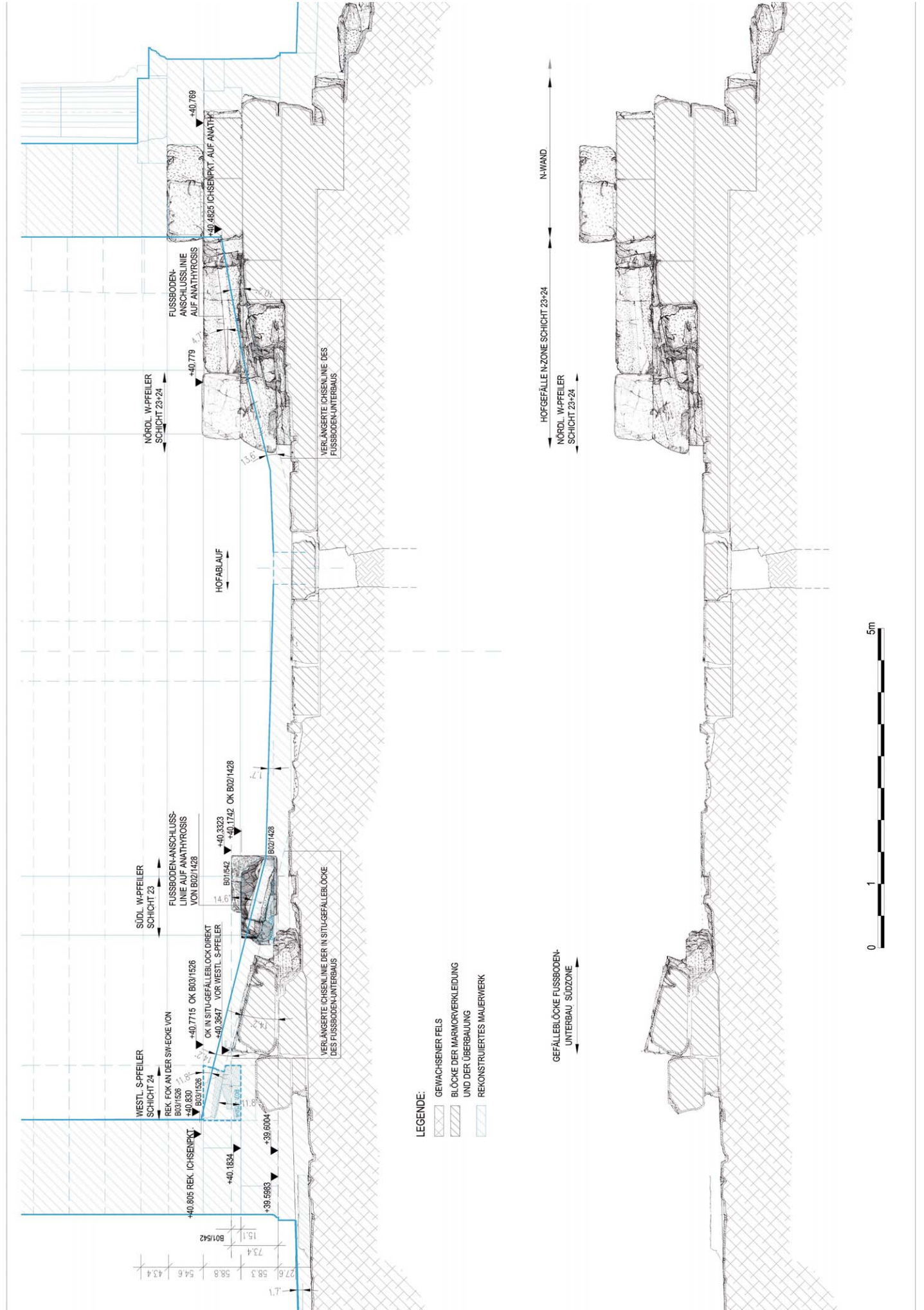

TAFEL 10

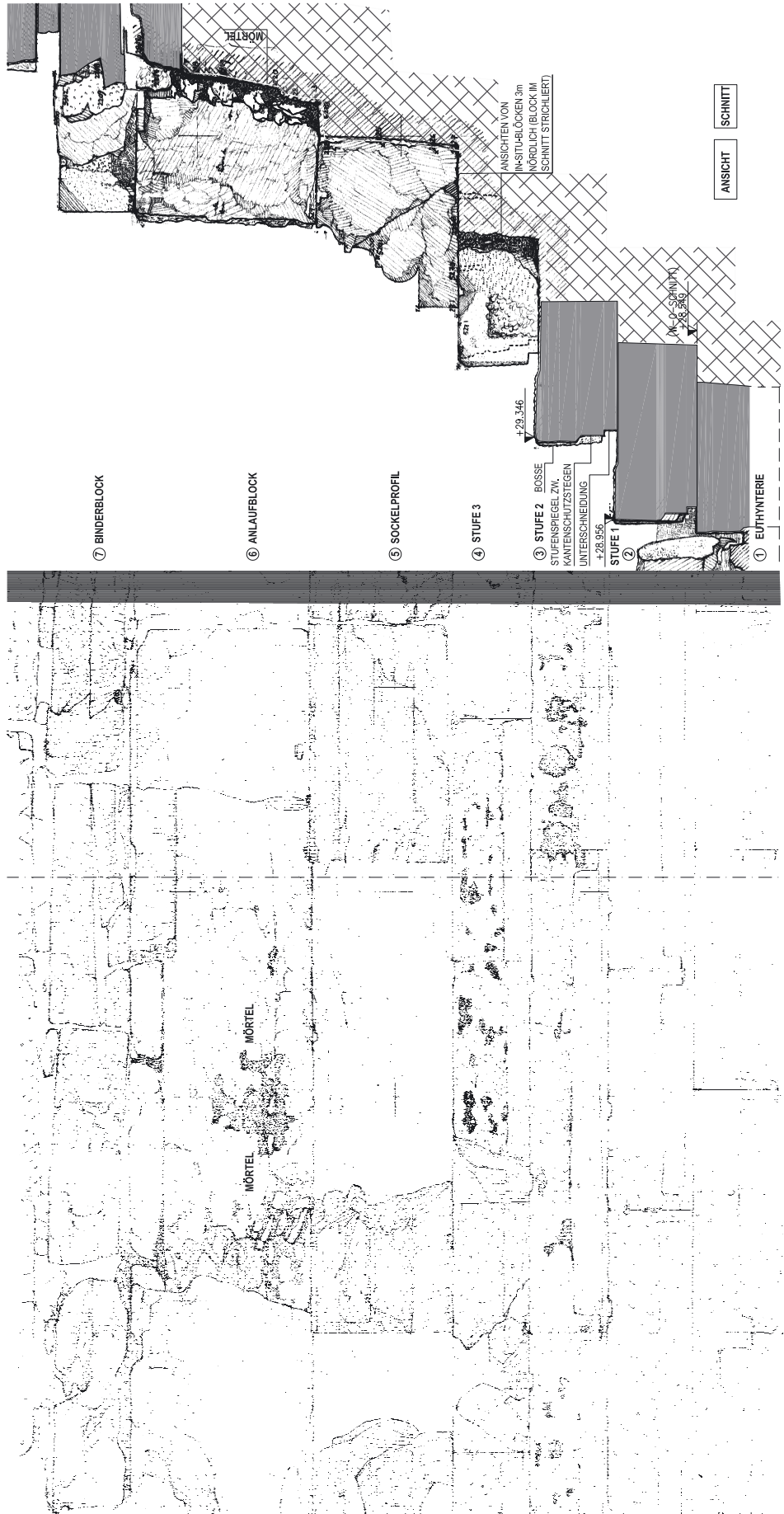

Krepis und untere Wandschichten vom Südteil der Westfassade. Bestandsplan M = 1 : 20.



1



2

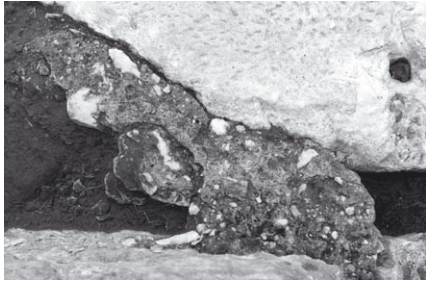

3



4

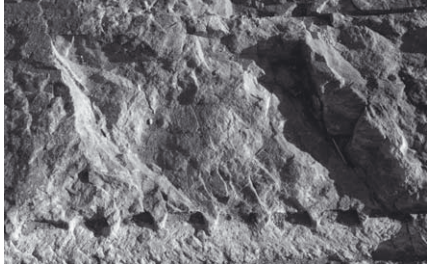

6

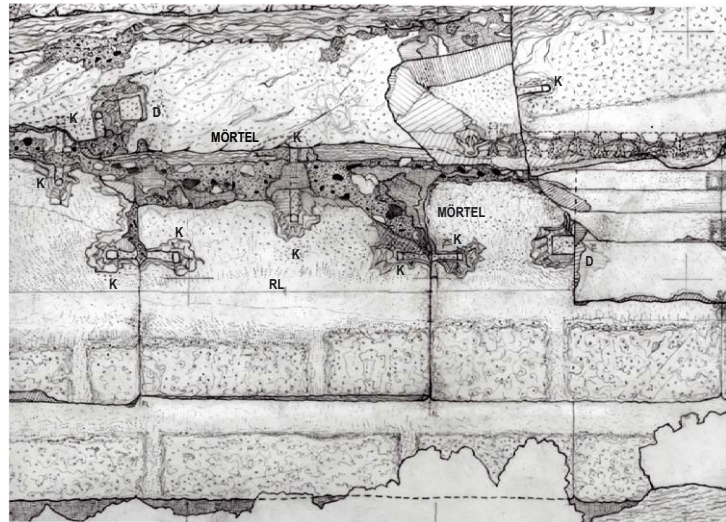

ANLAUF-BLOCK
SOCKEL-PROFIL
STUFE 3
STUFE 2
STUFE 1



7



8

1: Eckstufenfragment der Krepis B05/1674, O;
2: Krepis der Nordseite und Schwellbereich der Scheintür;
3-5: Krepis mit Mörtelhinterfüllung, nördliche Westseite,
3: Ausschnitt mit Mörtelverfüllung aus 4; 5: Zeichnung zu 4 mit Schicht 2-6, M = 1 : 20;
6: Sprengkeils Spuren am Felsplateau vor der Westseite;
7-8: Felswandausnehmung für einen Sockelprofilblock an der östlichen Nordseite;
9: Nordwest-Eckblock der ersten Krepisstufe mit Gusskanälen;
10: Nordost-Eckblock der Euthyterie, O mit Aufschnürungslinie;
11: Nordost-Eckblock der Euthyterie, R;



9



10

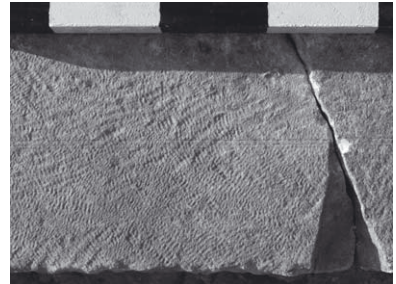

11

TAFEL 12



1

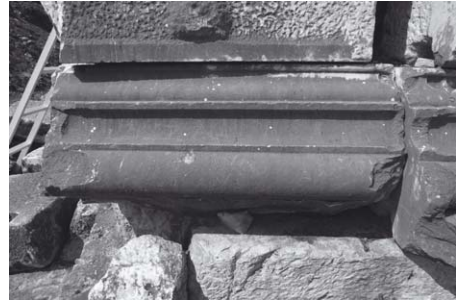

8



2



3



9

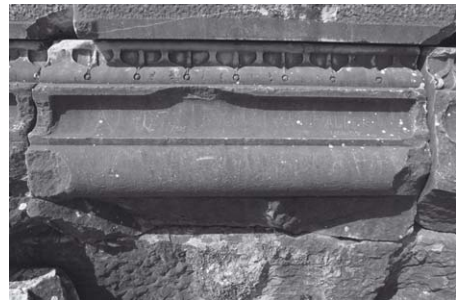

10



4



5



11



6



7



12

- 1: Krepis und Sockelprofil der Nordseite;
 2: Nordstecke in Richtung Ostseite;
 3: Hinterfüllungsmörtel hinter einem Sockelprofilblock der Westseite;
 4: Lesbisches Kyma des Sockelprofils, Westseite;
 5: Südwestecke, Aufsicht auf dislozierten Sockelprofilblock und Felslagerfläche;
 6: Aufschnürungslinien für die darüberliegende Schicht;
 7: Sockelprofilblock der östlichen Südseite;
 8–12: Sockelprofilblöcke der südlichen Ostseite mit fortschreitenden Ausarbeitungsstufen des lesbischen Kymas.



1



2



3



4



5

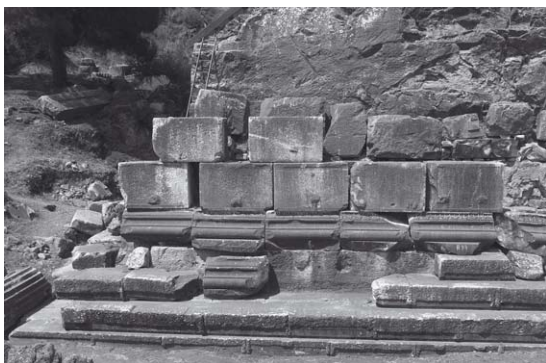

6

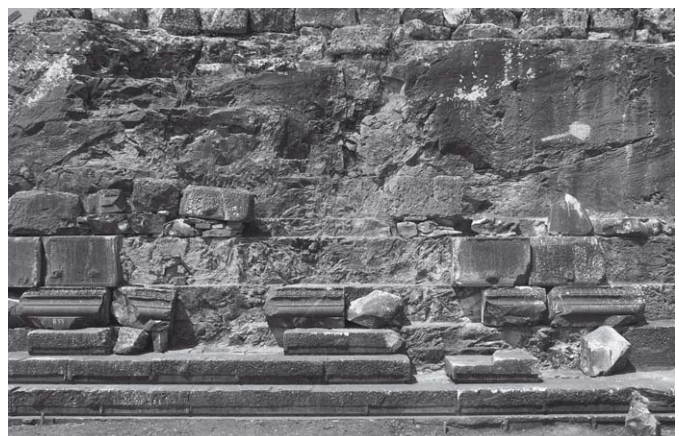

7

1-2: Felskernwände mit Klammernischen, südliche Westseite und westliche Südseite;
3: Nordwestecke;

4: Klammernische der Südseite mit Schwalbenschwanz-Klammerloch;
5-7 Teilansichten der Ostwand mit Lagerflächeneinarbeitungen im Fels.

TAFEL 14

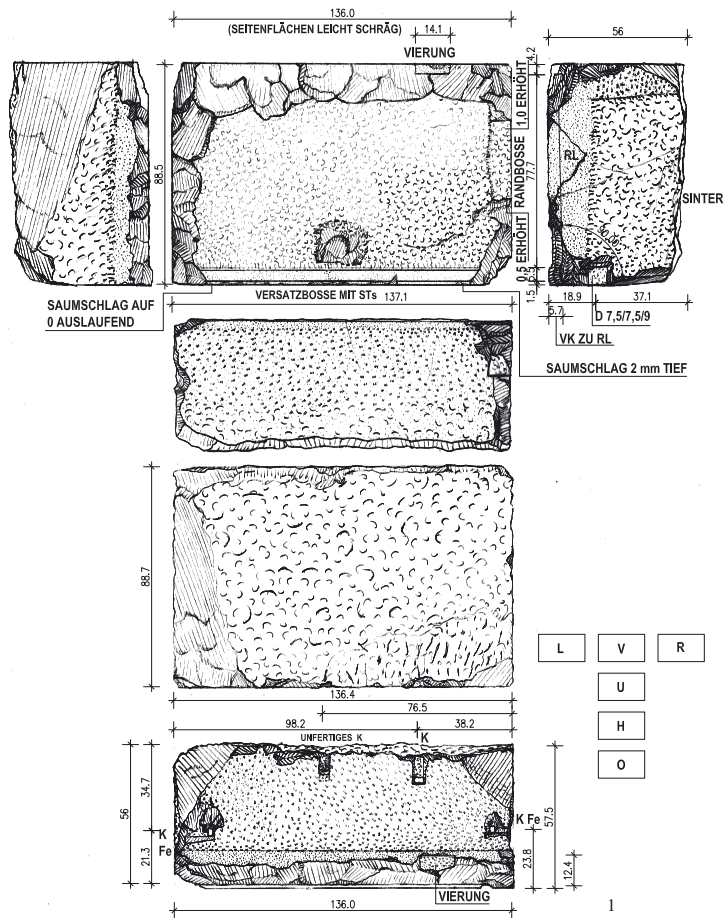

2



3



4



5



6



7

1-7: B00/41 Läuferblock, Schicht 6, Ostseite;
1: M = 1 : 20; 2: L; 3: R; 4: O; 5: Detail O Vierungsausnehmung; 6: U; 7: H.

TAFEL 16



1



2



3



4



5



6

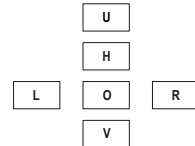
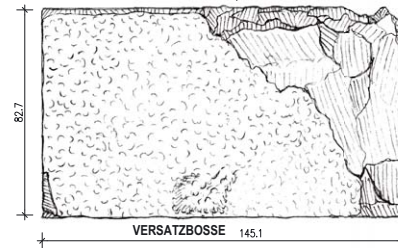
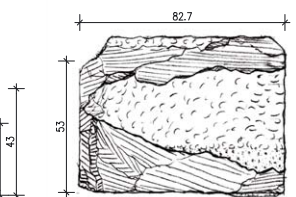
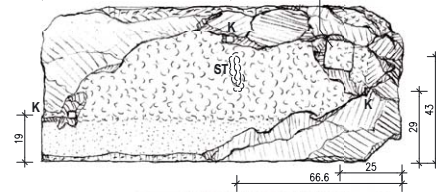
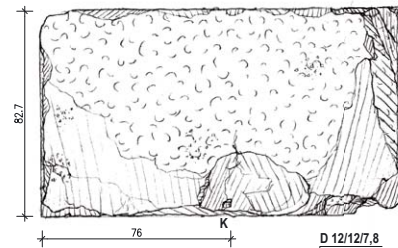
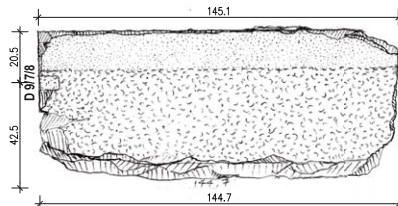
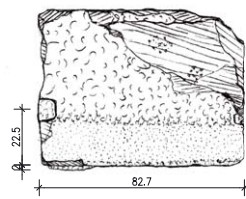

7

8

1–2: B03/1572 Läuferblock der Schicht 8, Eckanschlussblock nördliche Ostseite; 1: O; 2: V;
 3–8: B05/1676 Läuferblock der Schicht 8, Eckanschlussblock östliche Südseite; 3: U; 4: L; 5: H;
 6: R; 7: V; 8: M = 1 : 20.

TAFEL 18

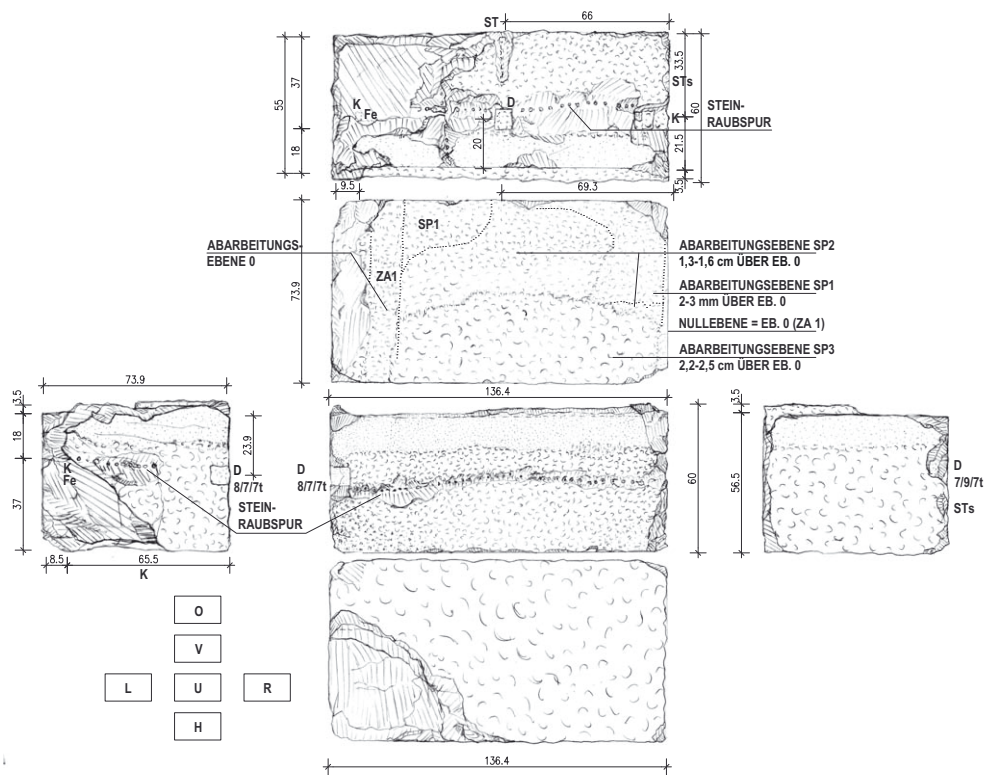
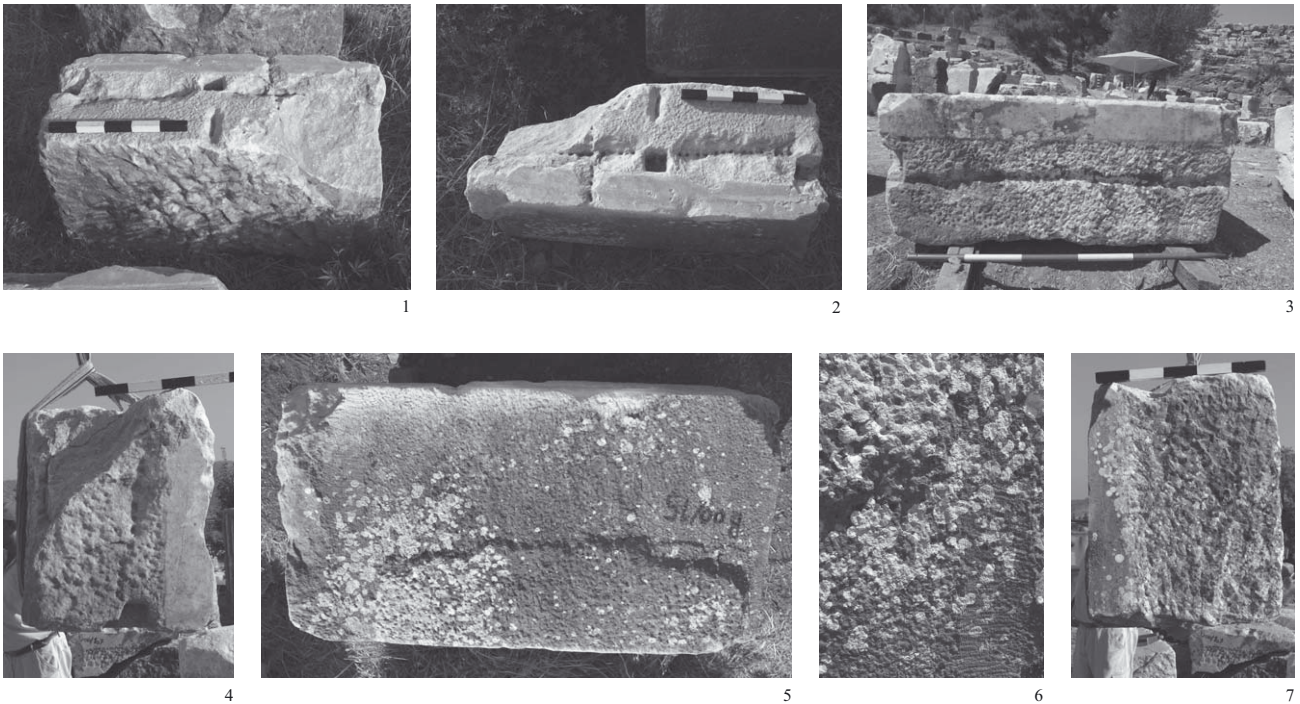

1-8: B00/15 Läuferblock der Schicht 12, Ostseite.
 1: H; 2: O; 3: U; 4: L; 5: V; 6: Detail V ZA-Streifen; 7: R; 8: M = 1 : 20.

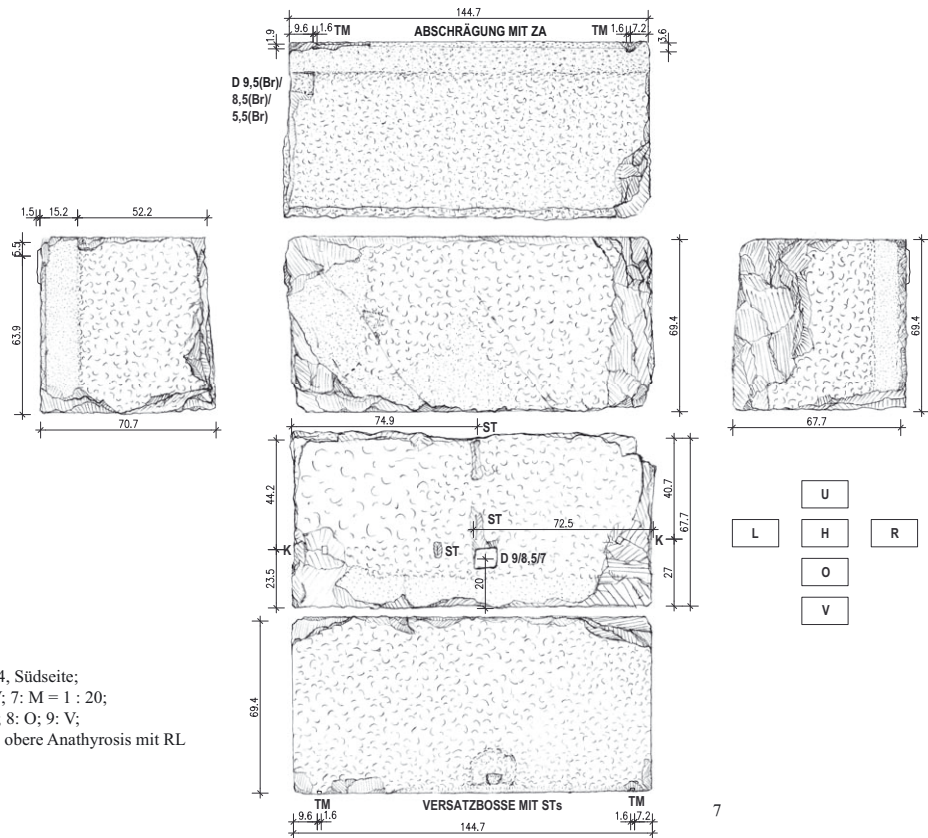
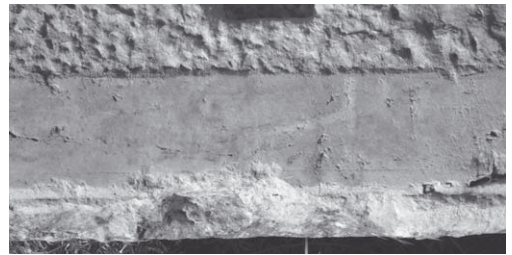
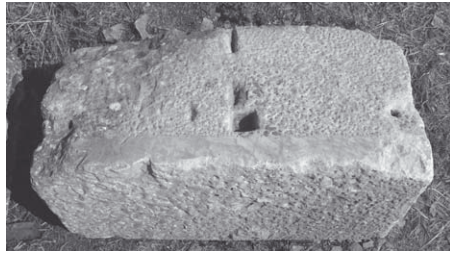
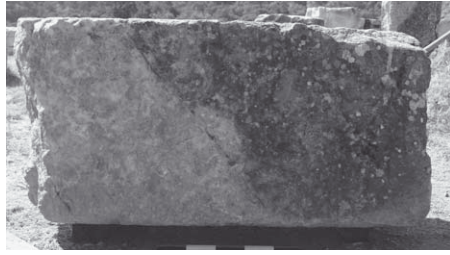

1-7: B05/1677 Läuferblock der Schicht 14, Südseite;
1: Kante zur V; 2: H; 3: R; 4: O; 5: L; 6: V; 7: M = 1 : 20;
8-9: B02/932 Läuferblock der Schicht 16; 8: O; 9: V;
10: B05/1683 Läuferblock der Schicht 16, obere Anathyrosis mit RL und TM.

TAFEL 20



1



2



3



4

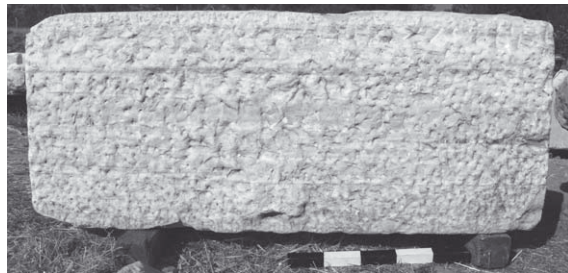

5



6



7

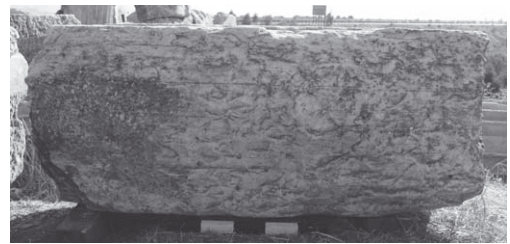

8

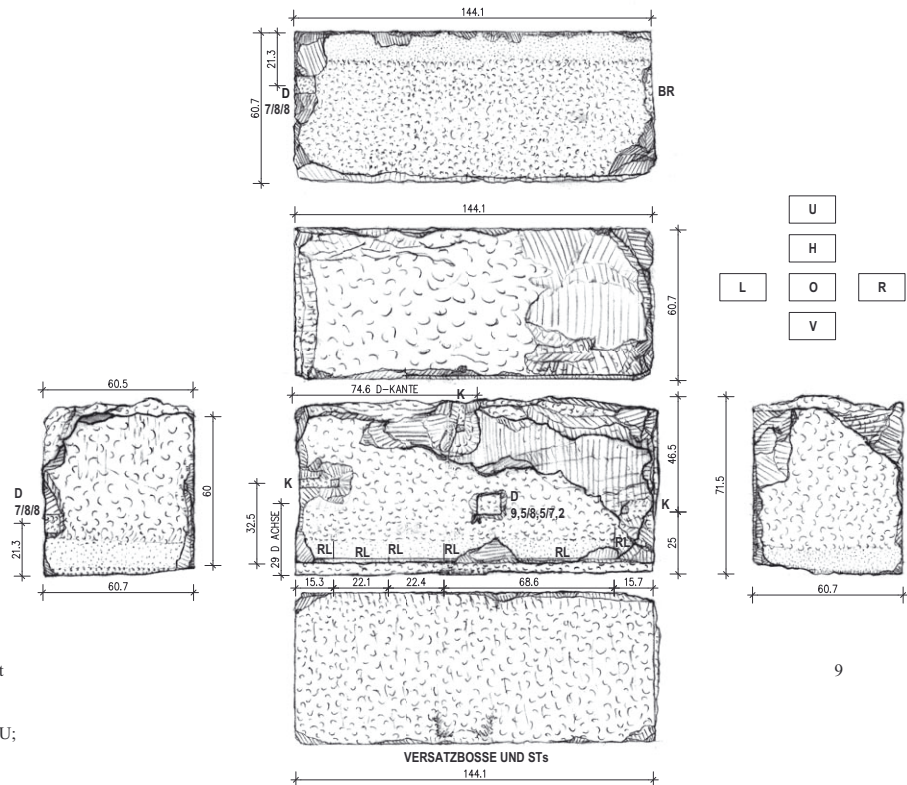

9

1–9: B05/1675 Läuferblock der Schicht 16, Südseite;
 1: O; 2: Versatzbosse auf V; 3: RL auf oberer Anathyrosis, 4: L; 5: V; 6: R; 7: U; 8: H; 9: M = 1 : 20.

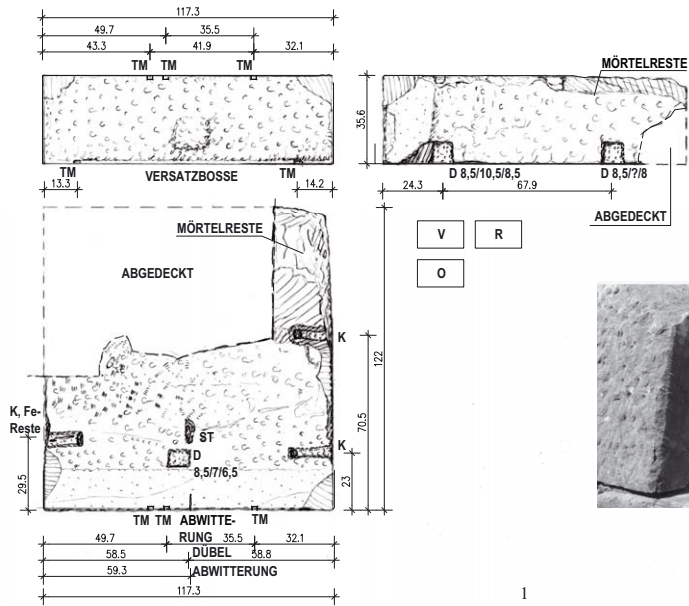

1

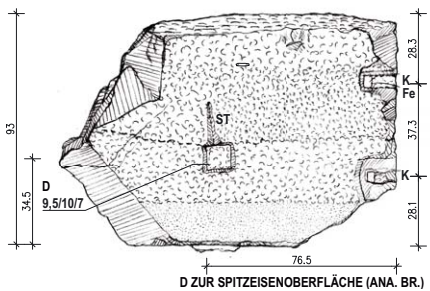
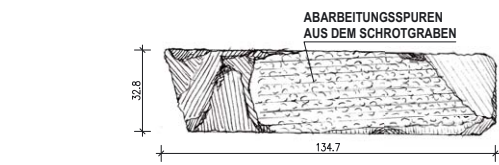
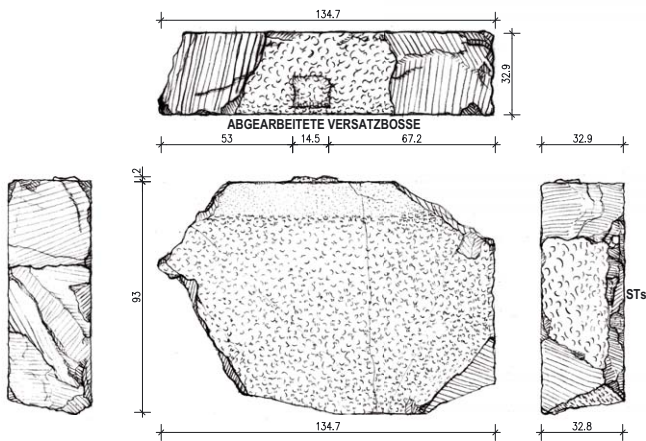

D ZUR SPITZEISENOBERFLÄCHE (ANA. BR.)

5

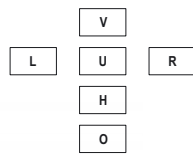

2



3



4



6



7



8



9



10

1-4: DW23 Binderblock der Schicht 7, Westseite; 1: M = 1 : 20; 2: V; 3: O; 4: R, Kante zur V;
5-10: B02/1318 Binderblock der Schicht 9, Nordseite; 5: M = 1 : 20; 6: R; 7: V; 8: U; 9: H; 10: O.

TAFEL 22

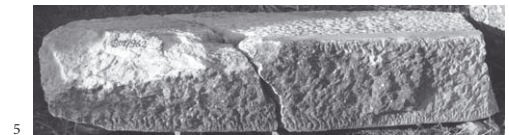
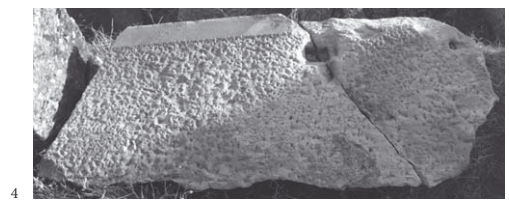
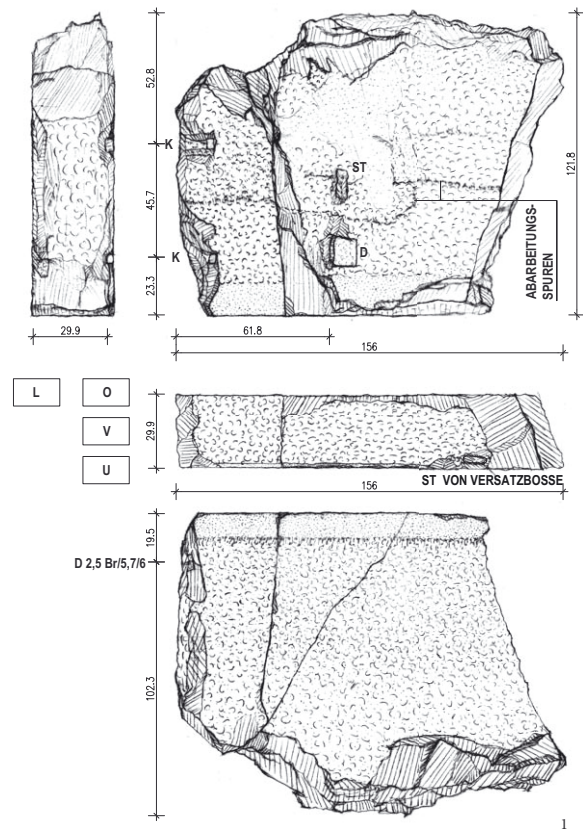

1-3: B02/680 A+B Binderblock der Schicht 13, Westseite, 1: M = 1 : 20; 2: O; 3: U;
 4-5: B02/962 Binderblock der Schicht 13, Doppelblock der Westseite, 4: O; 5: V;
 6-10: B02/904 Bindereckblock der Schicht 13, Südwestecke; 6: M = 1 : 20; 7: R; 8: O; 9: V; 10: U.

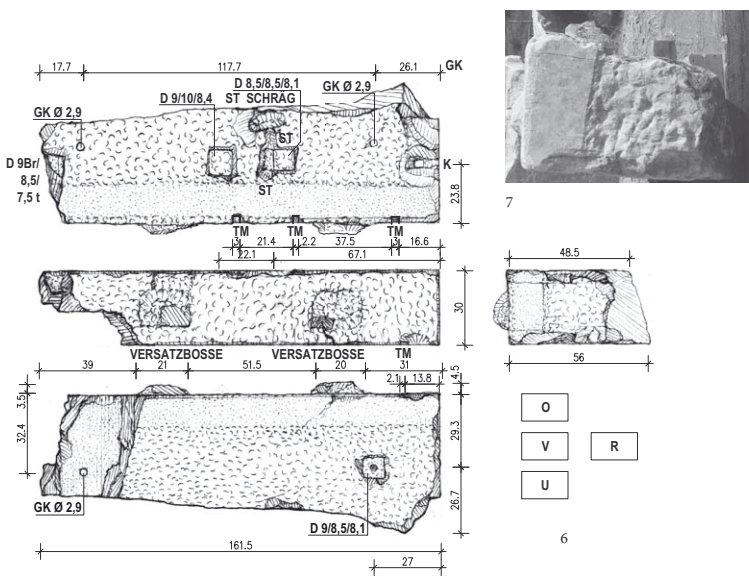

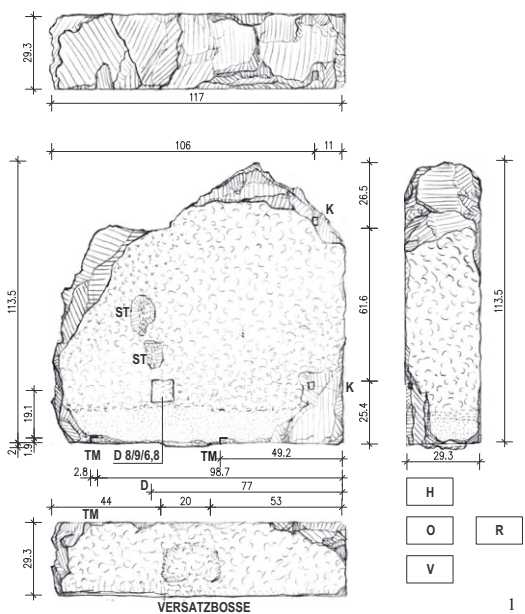

1–4: B02/1311 Binderblock der Schicht 15, Nordseite, 1: M = 1 : 20; 2: O; 3: V; 4: R;
 5: DS02 Läuferblock der hinteren Reihe, Schicht 8;
 6–8: DO-04 Läuferblock der Schicht 8, Ostseite, 6: linke Anathyrosis mit RL; 7: V; 8:
 TM auf der rechten Kante, V.

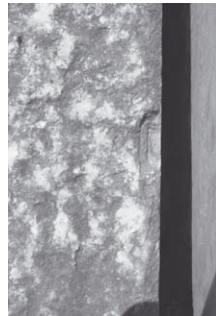
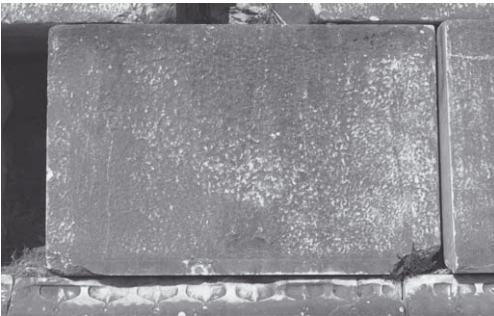
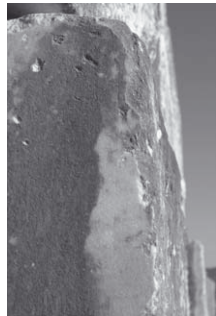

6

7

8

TAFEL 24

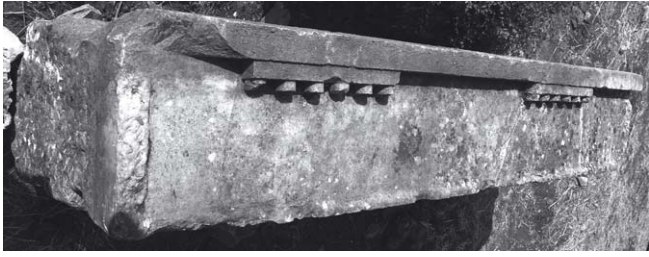

1

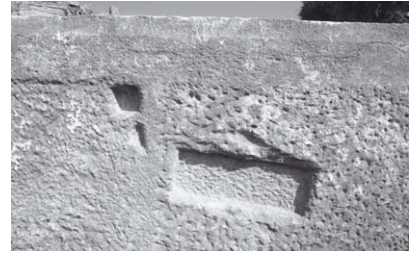

2

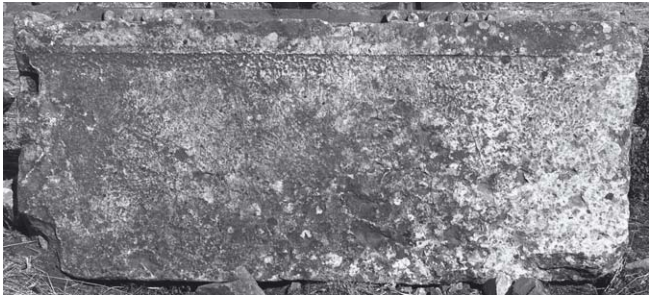

3



4

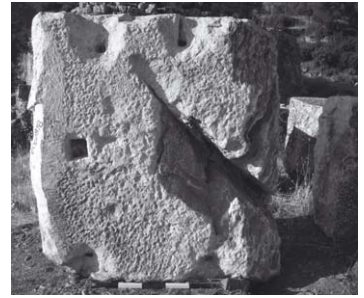

5



6



7



9



8



10

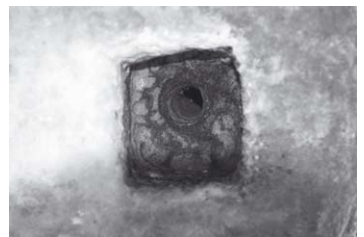

11

1–3: B02/1041 dorischer Wandarchitrav, Westseite, 1: L, V; 2: Detail O mit Ausbesserung; 3: U;

4: B02/1019 dorischer Wandarchitrav mit Reparaturverklammerung an der U;

5: B02/818 dorischer Wandarchitrav, O.

6–7: B02/788 Triglyphenblock; 6: V; 7: R.

8–11: B02/929 Ecktriglyphenblock, Nordwestecke; 8: O; 9: Wolfsloch Draufsicht, 10: Wolfsloch Schmalseite; 11: Innenliegendes Dübelloch mit Gusskanal, U.

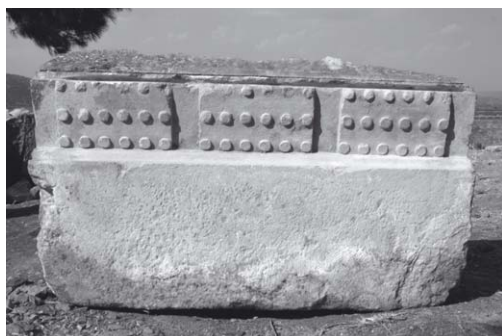

1



2



3



4



5

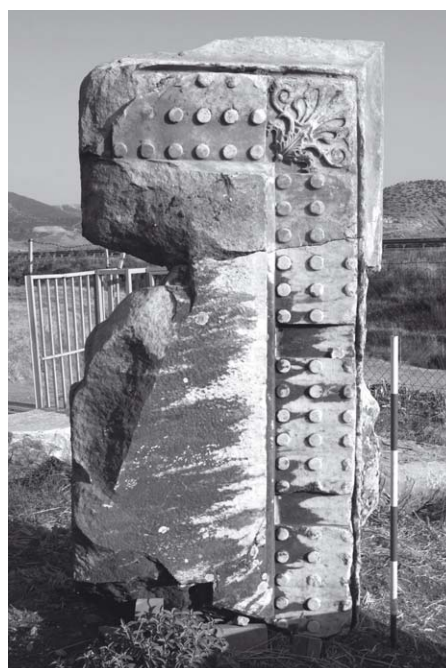

6



7



8

1-3: B02/792 dorisches Gesims, 1: U; 2: L; 3: O;
 4-8: B00/51+67 dorischer Eckgesimsblock (Siehe auch THEUER in: Belevi 1979, Abb. 14.1 Steinnr. 42); 4: O; 5: L; 6: U; 7: V Langseite; 8: Wolfsloch Aufsicht.

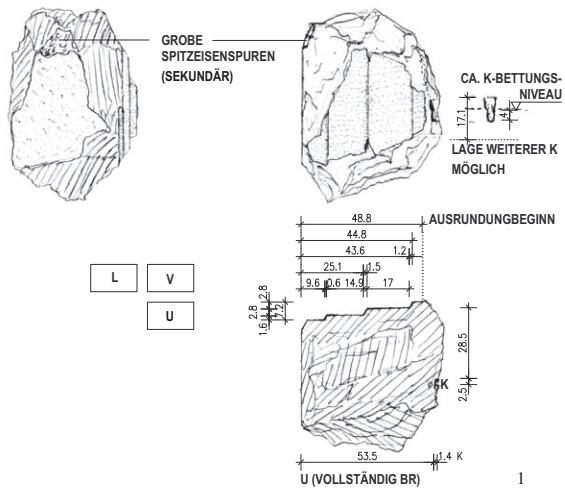

2

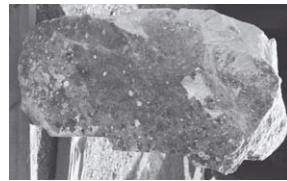
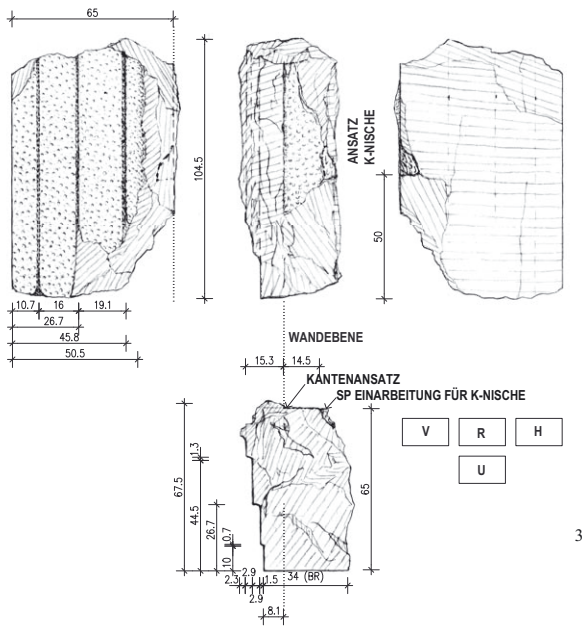

4



5

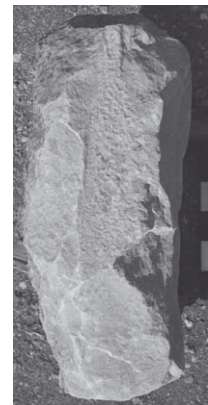

6

1-2: B01/500 rechter Gewändeblock der Scheintür, Bruchstück; 1: M = 1 : 20; 2: V;
3-6: D1314 rechter Gewändeblock der Scheintür, Bruchstück; 3: M = 1 : 20; 4: O (BR); 5: V; 6: R.

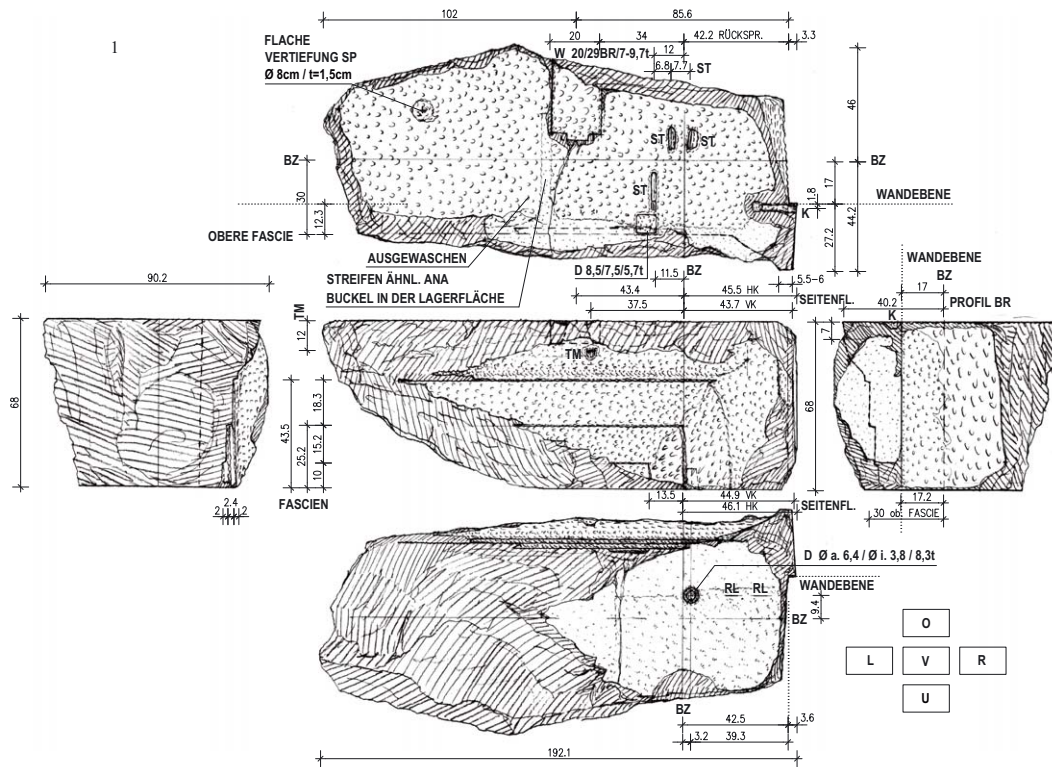

2



3



4



5

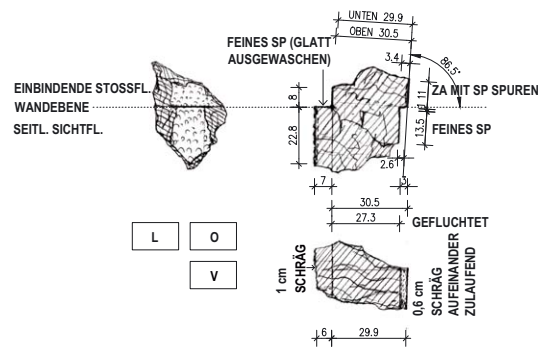

6

1-5: B01/488 Sturzblock der Scheintür, Bruchstück; 1: M = 1 : 20; 2: O; 3: Schrägsicht von rechts oben; 4: V; 5: U; 6: B01/499 Konsolenfragment der Scheintür, M = 1 : 20.

TAFEL 30

1: Felsausnehmung für Scheintür, Ausschnitt Lagerfläche Ebene 2;
 2-3: B02/1227 Bekrönungsprofil Scheintür; 2: M = 1 : 20; 3: V, U;
 4-8: B01/489 Bekrönungsprofil Scheintür; 4: L, V; 5: O; 6: V; 7: U;
 8: M = 1 : 20.

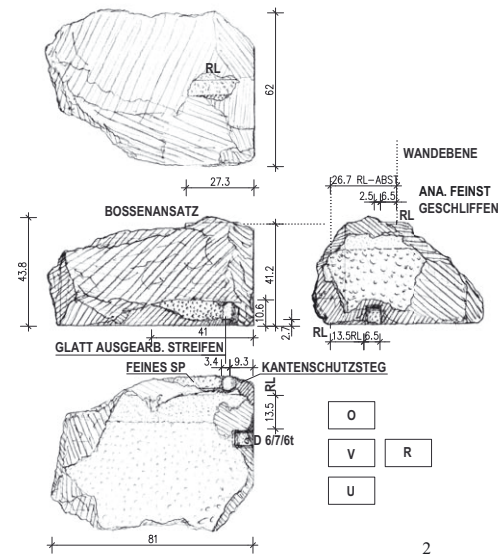

1



3



4



5

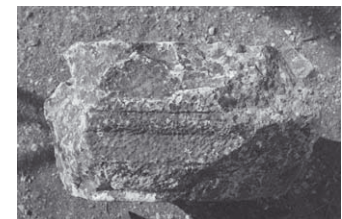

6



7

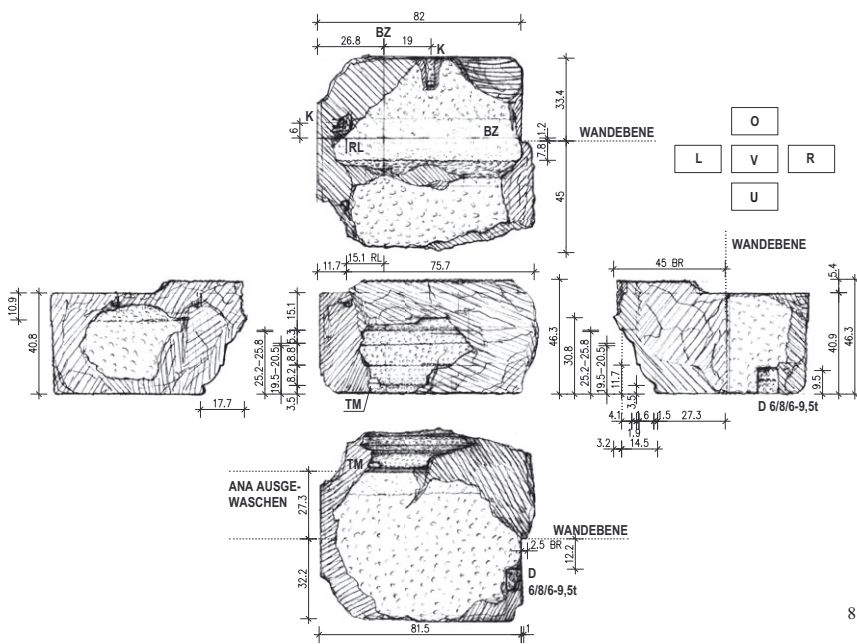

8



1



2



3



5



6



4



7



8

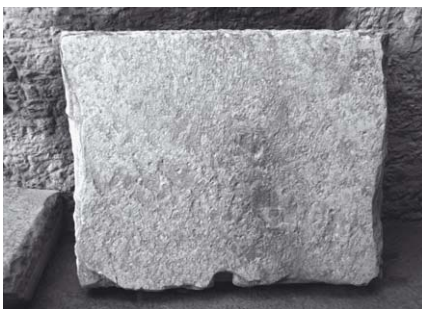

9



10

- 1: Grabkammereinschnitt von Süden;
 2: Sarkophagstandplatz mit anschließender Felsbank;
 3-4: Sarkophagstandplatz mit Ausnehmung, Sprengkeils Spuren und Schrotgrabenresten; 3: O; 4: von Süden;
 5: Südostecke der Vorkammer, Aufsicht;
 6: Nordwestecke der Vorkammer, Aufsicht auf den Stufen- und Sockellagerbereich;
 7: D1350 Bodenplatte der Grabkammer, H mit Mörtelresten;
 8: Grabkammer Nordwestecke, Bodenplatte *in situ*;
 9: D1335 Bodenplatte der Grabkammer; U;
 10: D1354 Bodenplatte der Grabkammer, V.

TAFEL 32

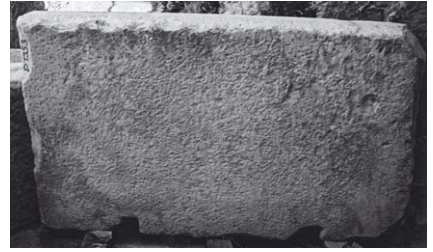
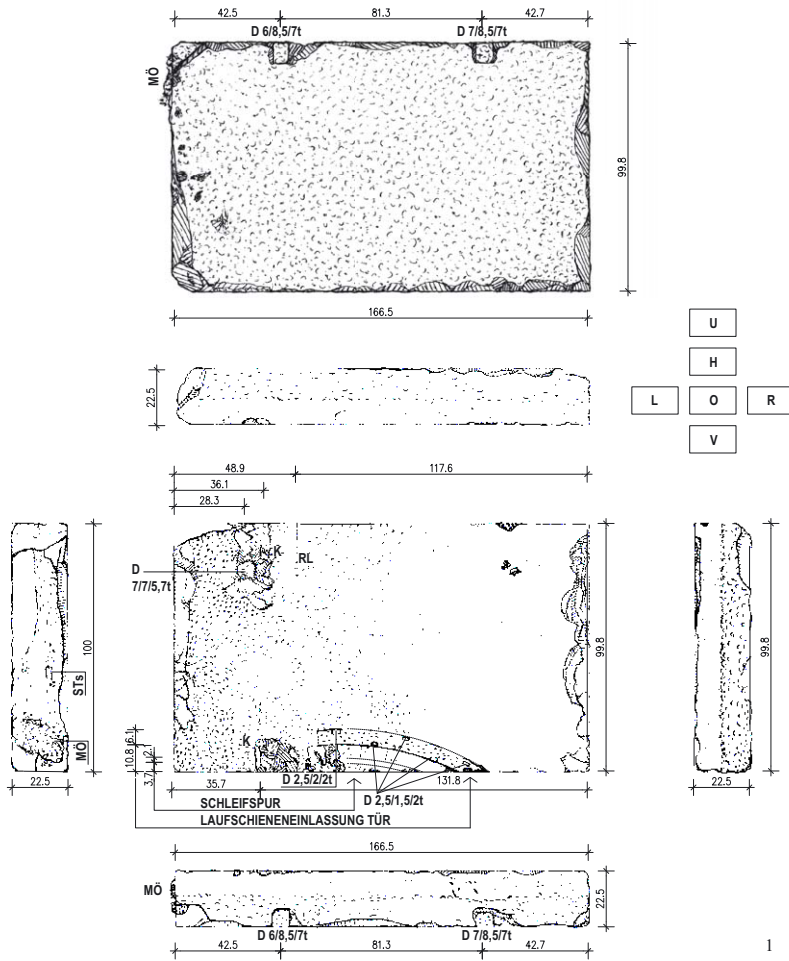

2



3

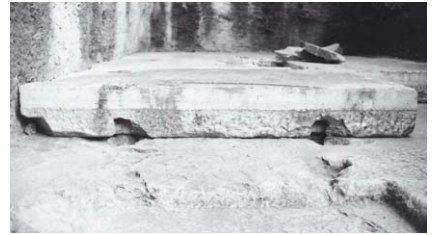

4



5

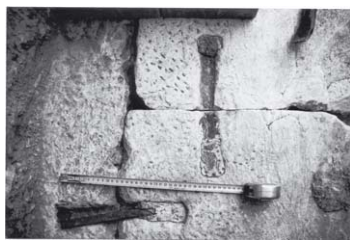

6



7



8



9

1–4: D1353 Bodenplatte der Grabkammer mit Türlaufschieneneinlassung; 1: M = 1 : 20; 2: U; 3: O; 4: V; 5: D1343 Felsbankdeckplatte an *in situ*-Bruchstück angepasst; 6: Felsbankdeckplatten, Anbindung an Felskernstufung; 7–9: Grabkammer und Felsbank mit wiederversetzten Bodenplatten und Wandverkleidungsblöcken; 7: Blick nach Nordwesten; 8: Nordteil Blick nach Westen; 9: Felsbank Aufsicht.

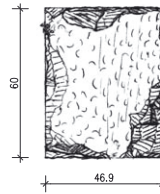
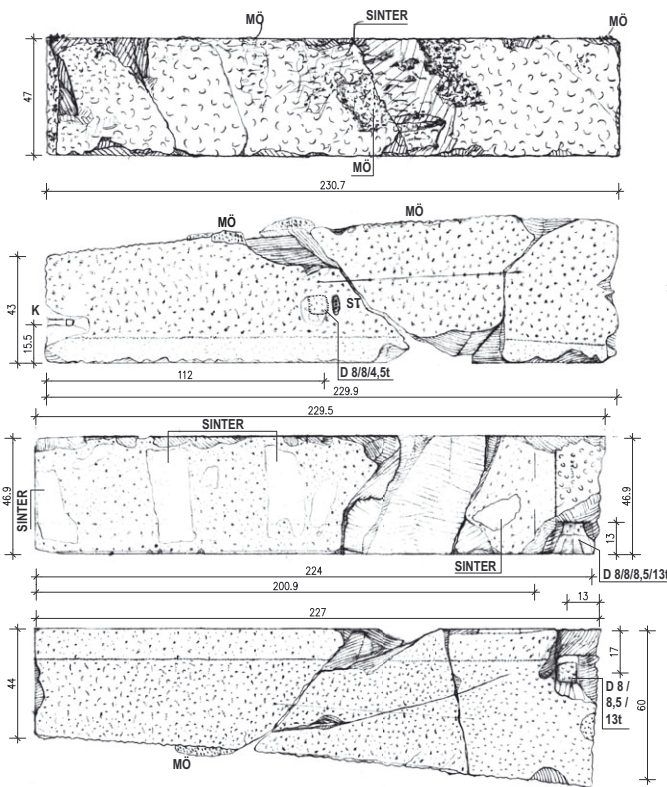

H	
O	R
V	
U	

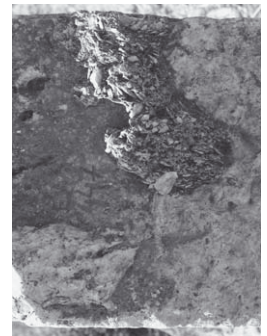

1–2: Grabkammer und Felsbank mit wieder-versetzten Bodenplatten und Wandverkleidungsblöcken; 1: Blick nach Norden; 2: Blick nach Südosten;
 3–7: B01/445+446+447 Wandblock Schicht G3;
 3: M = 1 : 20; 4: H; 5: R; 6: U (B01/447);
 7: Mörtelreste auf H;
 8: Südostecke der Vorkammer, Schicht G3, O;
 9: B01/592-1 Wandblock der Westseite der Grabkammer, Schicht G3.

TAFEL 34

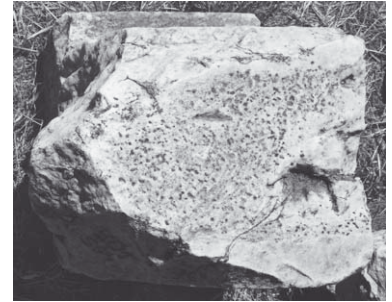
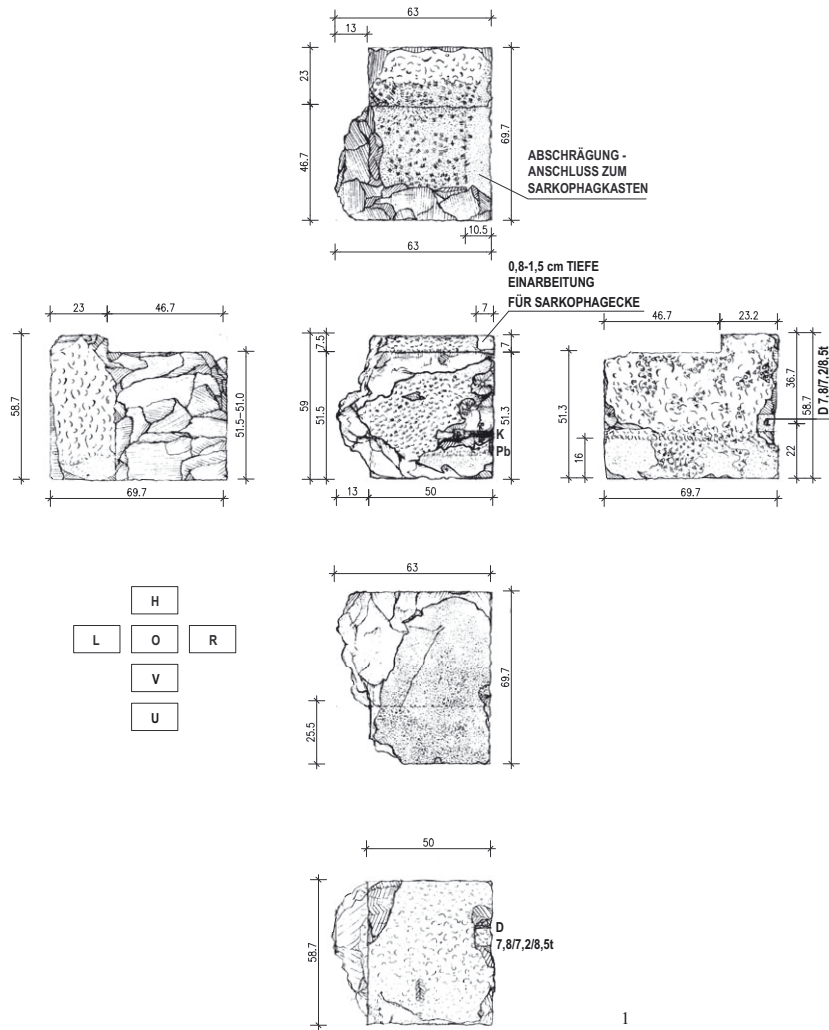

2

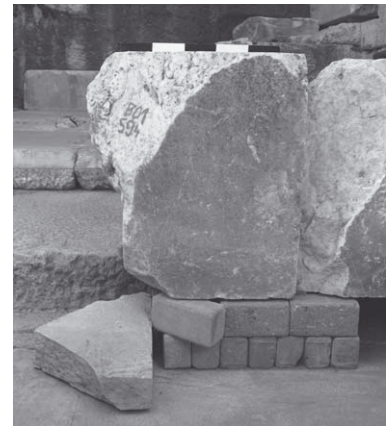

3



4



5



6

1-6: B01/594-1 Trennwandblock Schicht G3 mit Gewändeanschluss; 1: M = 1 : 20; 2: O; 3: V_{VORK.}; 4: L (West); 5: R (Ost); 6: V_{GRABK.}

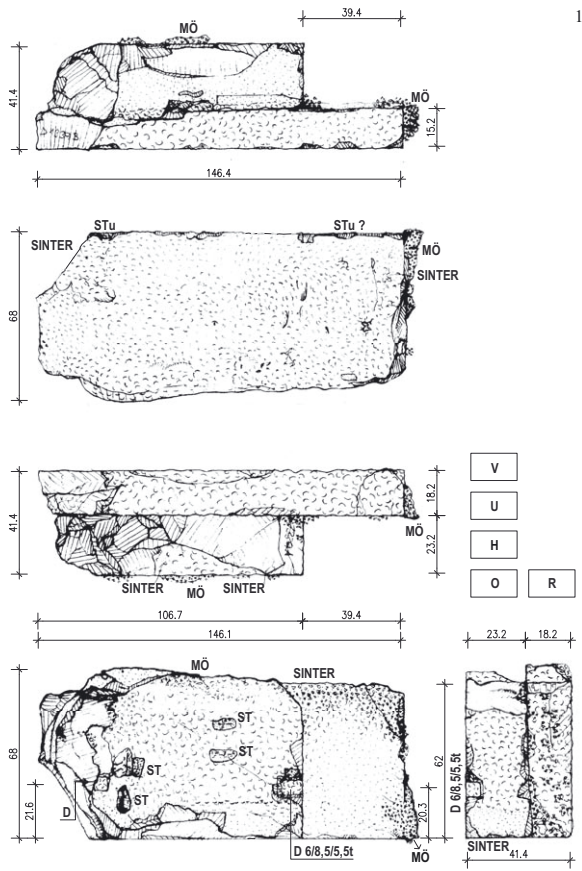

2



3

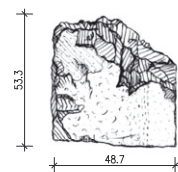
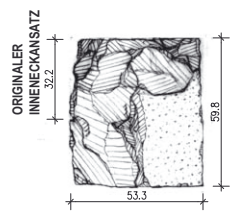
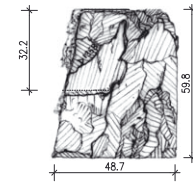
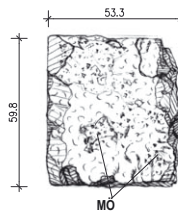
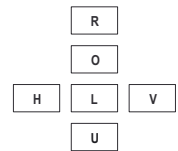
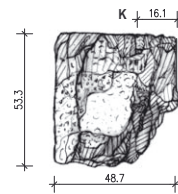
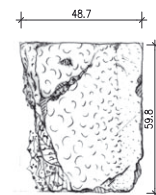

7



4



5



6

1-2: D1339A+B Wandeckblock Schicht G4, Nordostecke; 1: M = 1 : 20; 2: V;
 3: Ostwandansicht Grabkammer, Nordteil;
 4: B03/GR01 A+B+C Profilfragment, Streufund aus der Grabkammer;
 5: Ostwandblöcke der Grabkammer, Schicht G4 und G5; R.
 6: Ostwandansicht Grabkammer, Südteil;
 7: D1358 Wandblock Schicht G5, Südwestecke Grabkammer, M = 1 : 20.

TAFEL 36



1



3



4



5



6



7



8



9

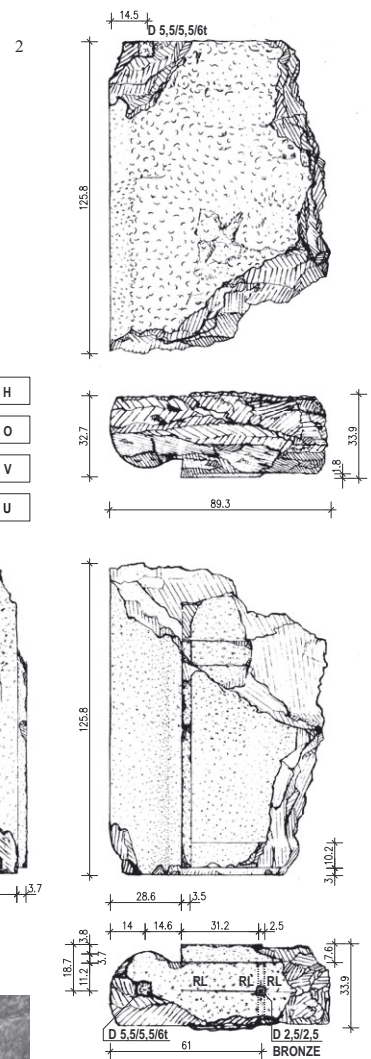

1: Sarkophagdeckel Kopfteil, R, zur Trennwand gerichtete Stoßfläche;
 2-6: D1356+B03/1579 Grabkammertür; 2: M = 1 : 20; 3: V; 4: H; 5: U; 6: B03/ GR70 Fragment
 des Mittelpostens;
 7: Krepisstufen im Bereich des Grabkammerzugangs;
 8: Südwall der Vorkammer;
 9: Grabkammerzugang in der Südwall, östliche Laibung.

TAFEL 38

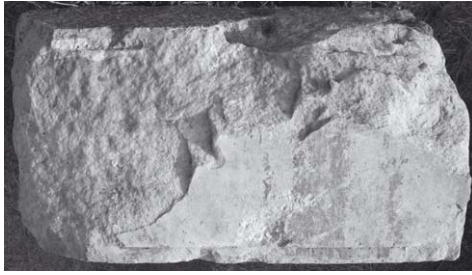

1



2



3



4



5



6



7



8



9

1–2: B01/451 Keilstein, Gewölbeanfänger
Schicht G7, Ostseite; 1: V; 2: R;
3–10: zweite Keilsteinreihe Schicht G8,
Westseite, Architekturprobe B01/449 –
B01/448 – B01/450; 3: Quaderungen,
Oberflächenstruktur mit erkennbaren
Kantenschlägen von B01/448 – B01/450;
4: L, O; 5: V, O; 6: H; 7: B01/450, L; 8:
B01/450, V; 9: B01/450, R; 10: B01/450, U.



10

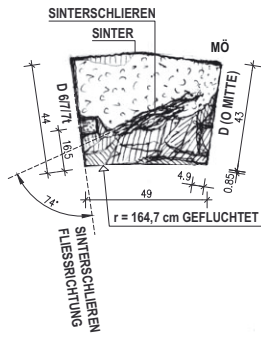
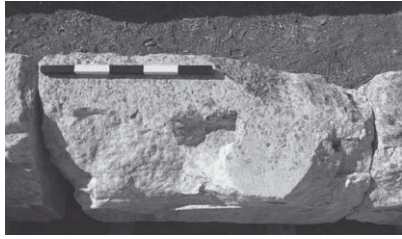

3



4



6



7



8

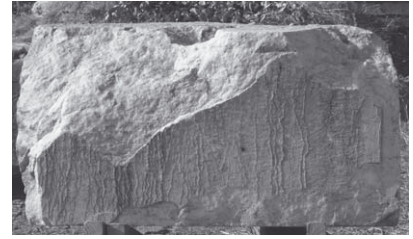

2

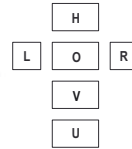
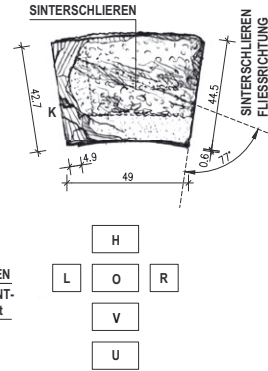
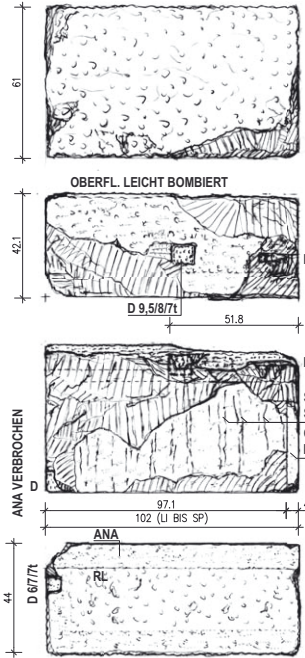

5

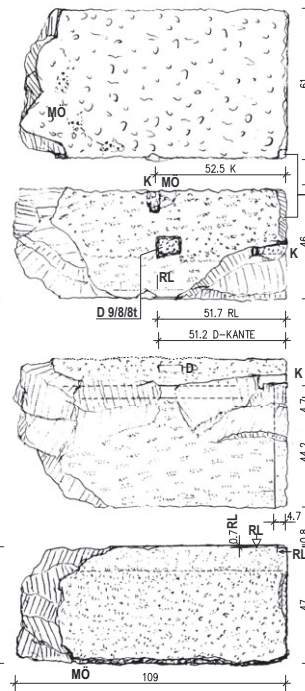

GK-ARTIGE EINARBEITUNG MIT MÖRTEL VERFÜLLT

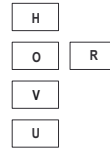
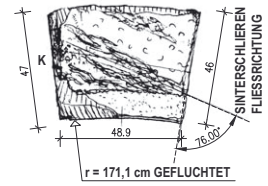

9

1-5: zweite Keilsteinreihe Schicht G8, Westseite, B01/448; 1: O; 2: V; 3: R; 4: U; 5: M = 1 : 20;
6-9: zweite Keilsteinreihe Schicht G8, Westseite, B01/449 6: V; 7: O; 8: R; 9: M = 1 : 20.

TAFEL 40



1



2



3

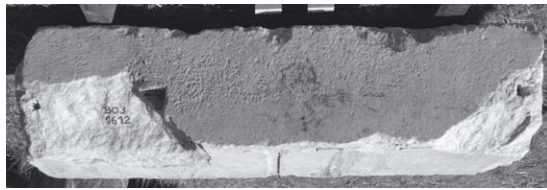

4



5



6



7



8



9

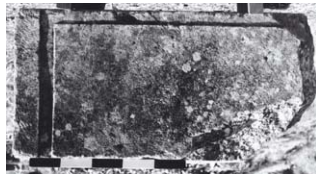

10



11

1–6: dritte Keilsteinreihe Schicht G9, Westseite, B03/1612 1: H über B01/448 – B01/450; 2: O, V; 3: L; 4: O; 5: R; 6: U;
7–11: zweite oder dritte Keilsteinreihe, Ostseite, B01/360; 7: O, V; 8: H; 9: L; 10: V; 11: U.



1

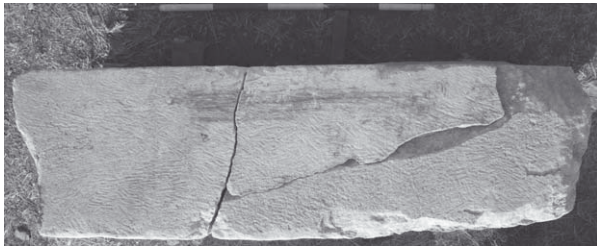

2



3

1-9: Keilstein Ostseite,
D/1337+1338+B03/1585;
1: V; 2: U; 3: H; 4: M = 1 : 20; 5: R; 6: L,
7-8: Versatzklammer an der Stoßkante
links unten zur H hin verlaufend, neben
seitlichem ST, 9: Mörtelreste auf der H.



5

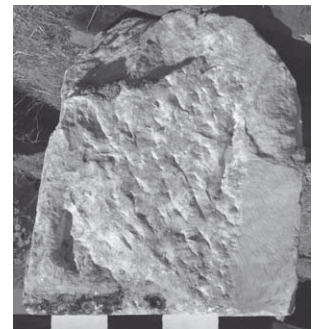

6

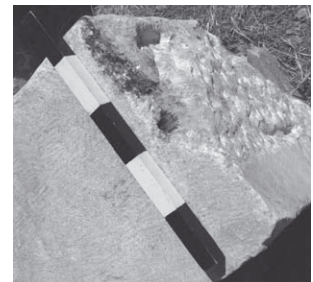

7



8



9

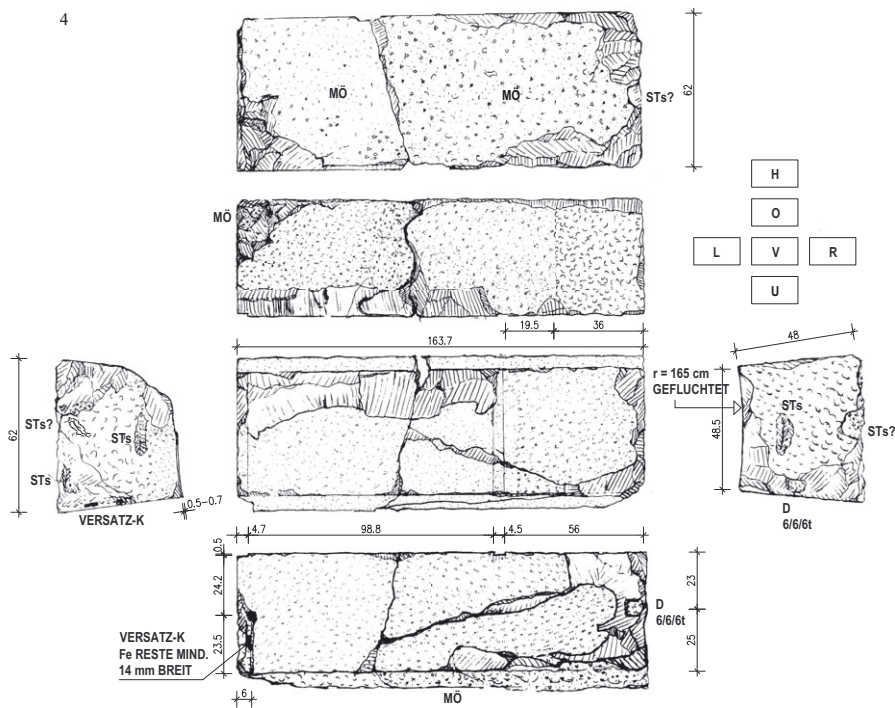

TAFEL 42

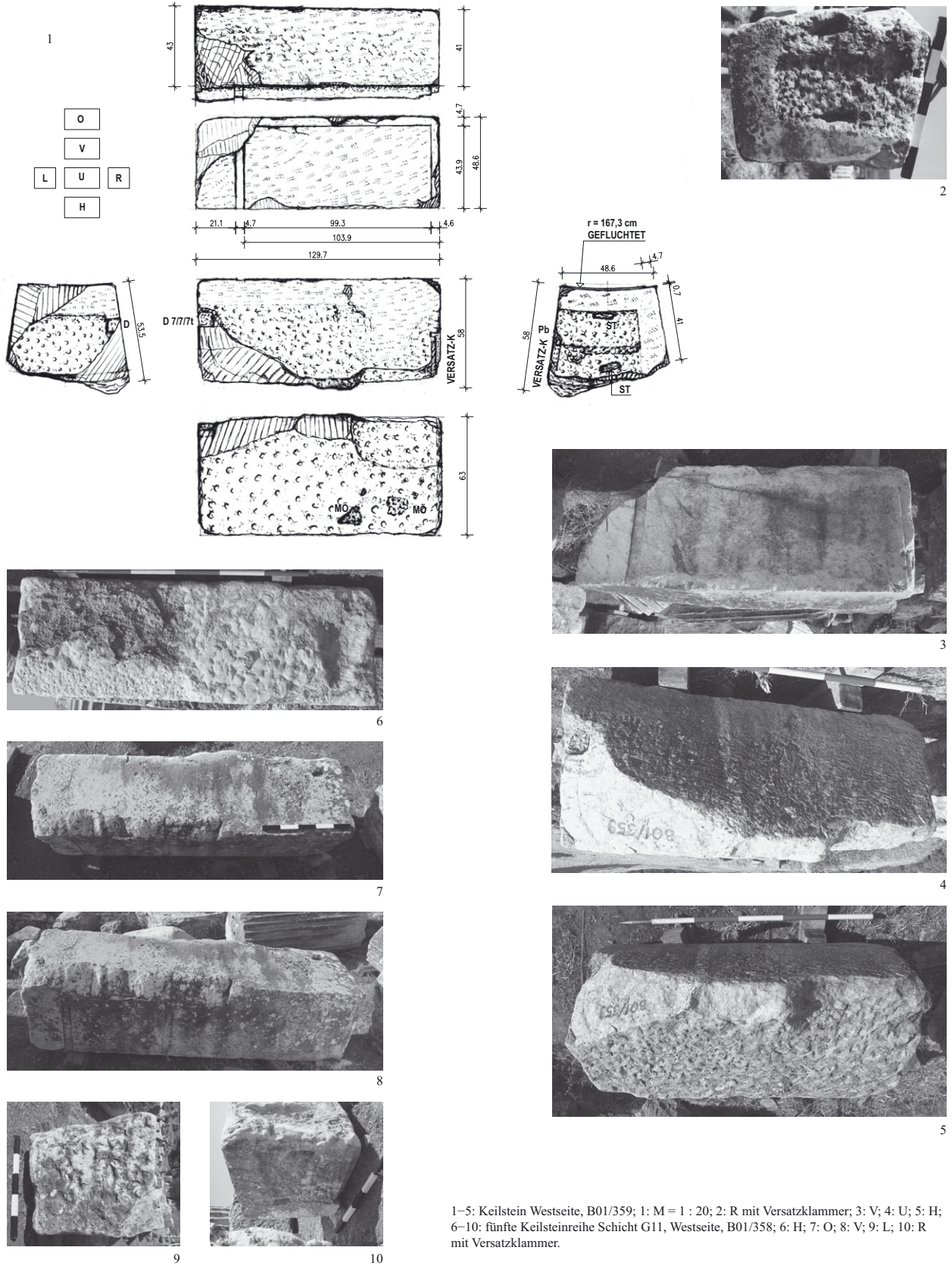

1-5: Keilstein Westseite, B01/359; 1: M = 1 : 20; 2: R mit Versatzklammer; 3: V; 4: U; 5: H; 6-10: fünfte Keilsteinreihe Schicht G11, Westseite, B01/358; 6: H; 7: O; 8: V; 9: L; 10: R mit Versatzklammer.



1



2



3



4

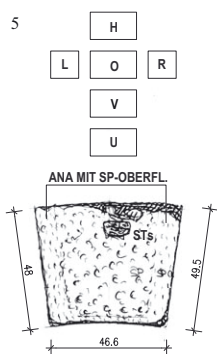

6

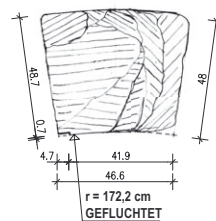
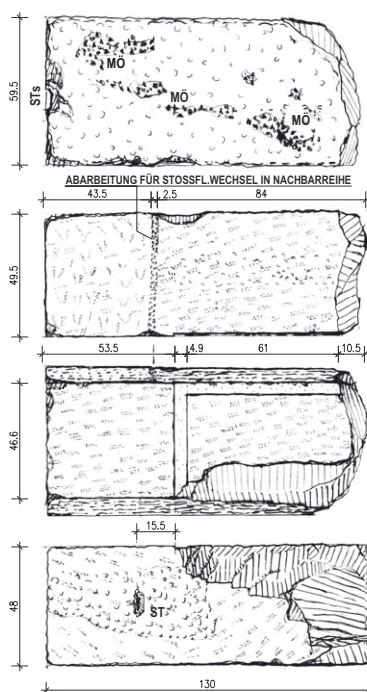

7



8



9

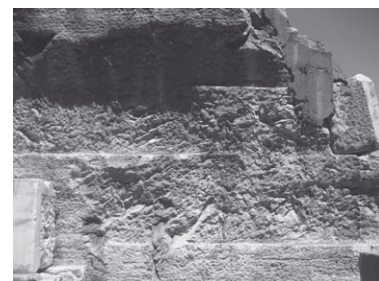

10

1–4: vierte Keilsteinreihe Schicht G10, Westseite mit Einbindung in die nördliche Stirnwand, B01/362; 1: O, V; 2: R; 3: H; 4: U;

5–7: vierte Keilsteinreihe Schicht G10, Westseite, B01/363; 5: M = 1 : 20; 6: L; 7: V, U;

8: Nördliche Stirnwand der Grabkammer, Felsfront im Gewölbereich;

9–10: Östliche Felswand der Grabkammer, Abarbeitungen für die Wandverkleidungsblöcke und Gewölbeanfänger bei Stoß- und Lagerfugen; 9: nördlicher Teil Grabkammer, 10: Vorkammer.

TAFEL 44



1

1-5: B01/595-1 Stirnwandblock der Vorkammer, Südseite; 1: O; 2: V; 3: R; 4: H; 5: U;
 6-8: B03/1613 Stirnwandblock der Vorkammer; 6: V, O (BR), R; 7: V; 8: L, O (BR);
 9-10: AL 12/76 Stirnwandblock der Grabkammer; 9: V; 10: Umriß V, U, M = 1 : 5;
 11: Entlastungszone über der Grabkammer, Westseite;
 12: Entlastungszone über der Grabkammer, oberer Abschluss mit Schichten der Felskernüberbauung;
 13: D1357 Wandblock der Vorkammer Schicht G3, Südwestecke, V mit Kantenschlagspuren;
 14: Architekturprobe B01/592-1 – B01/593-1 Wandblöcke der Grabkammer Schicht G3, Westseite, mit fugenübergreifenden Zahneisen Spuren.



6



2



3



4



7



8

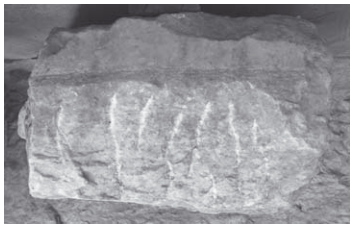

5

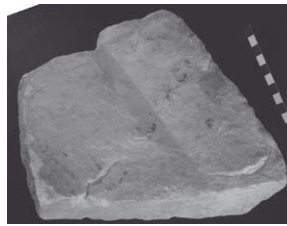

9



11

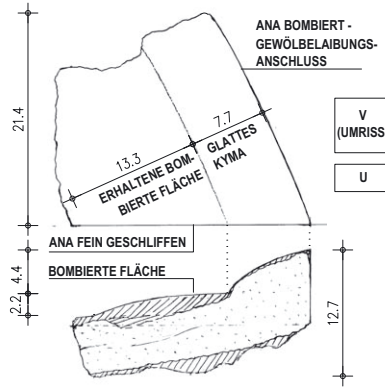

10

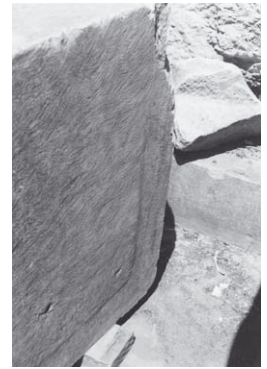

13



12

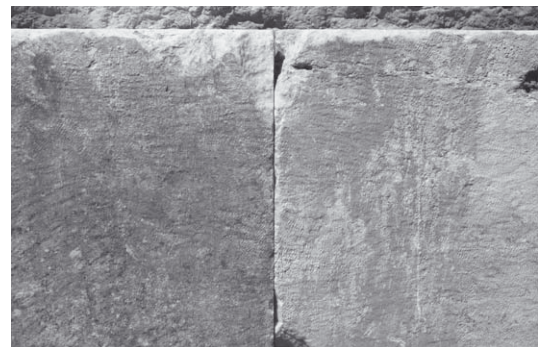

14



1



3

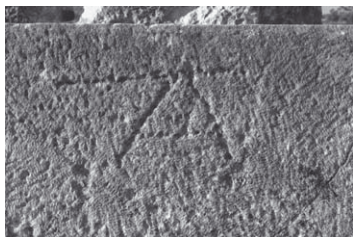

5



6

1-4: Felsplateau unter dem Peristasisboden, Südwestecke; 1: südliche Westseite, rechts die Felsbank auf Stylobatniveau; 2: südliche Richtung, rechts die Felsbank auf Stylobatniveau; 3: Felsbank auf Stylobatniveau von Süden gesehen; 4: Felskern, obere Südwestecke von Süden mit anstehender Felsbank; 5-11: B01/528 unterer Stufenstein des Stufenunterbaus der Krepis, Schicht 20; 5: Versatzmarke an der Unterseite; 6: R; 7: L; 8: M = 1 : 20; 9: O; 10: V; 11: U.



2



4

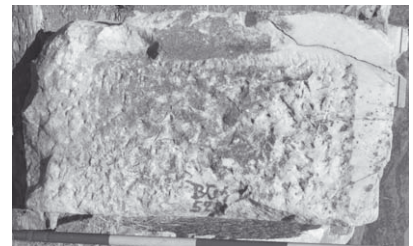

7

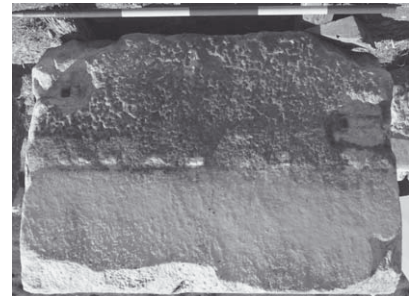

9



10



11

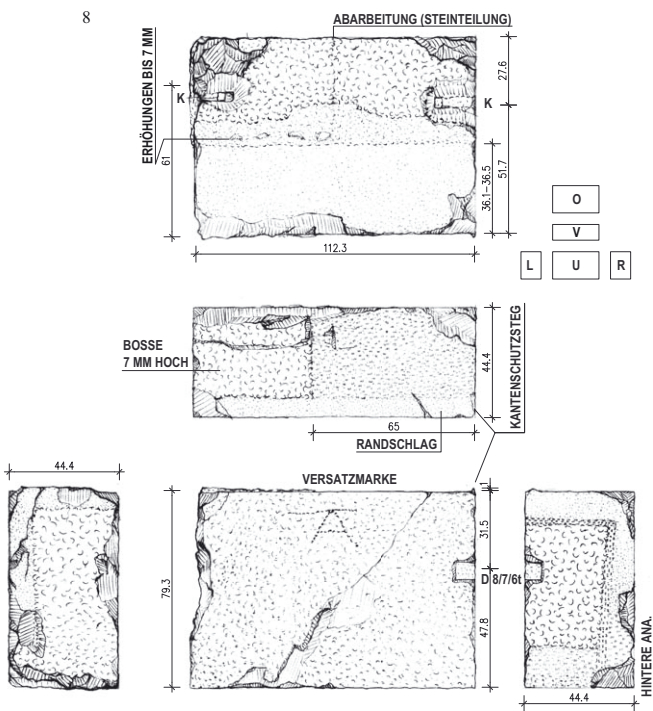

TAFEL 46

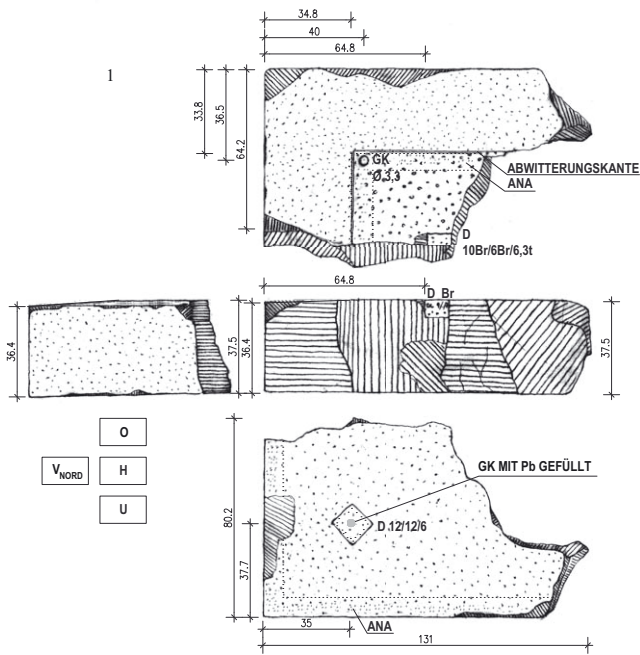

2

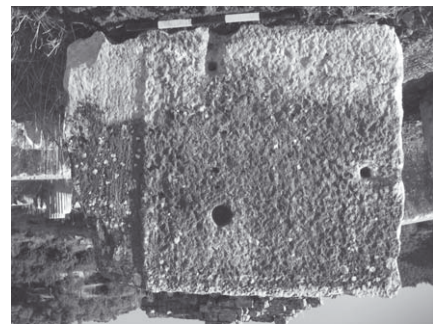

3

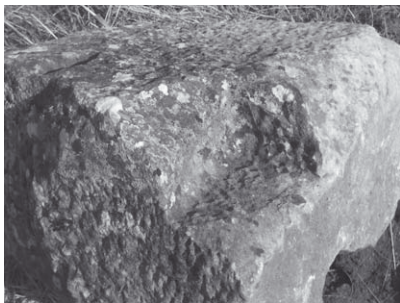

5

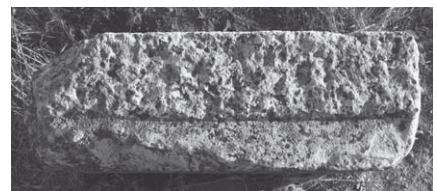

4



7



6



8

1-2: mittlere Stufensteine des Stufenunterbaus der Krepis, Schicht 21; 1: B01/442, O, V_{NORD}, H, U, M = 1 : 20; 2: DS24, O;
 3-4: B01/525 Stylobatblock der Peristasis; 3: O; 4: V;
 5-6: B02/973 Stylobatblock der Peristasis, Bruchstück linker hinterer Teil mit Einarbeitung; 5: H, L; 6: O;
 7-8: B02/1333 Stylobatblock der Peristasis, Bruchstück linker Teil mit Einarbeitung; 7: H; 8: O.

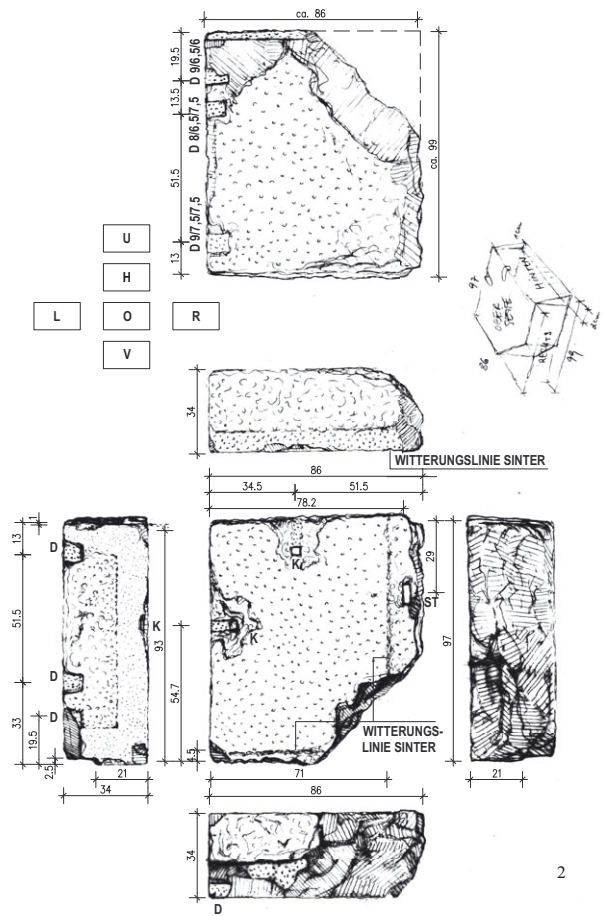
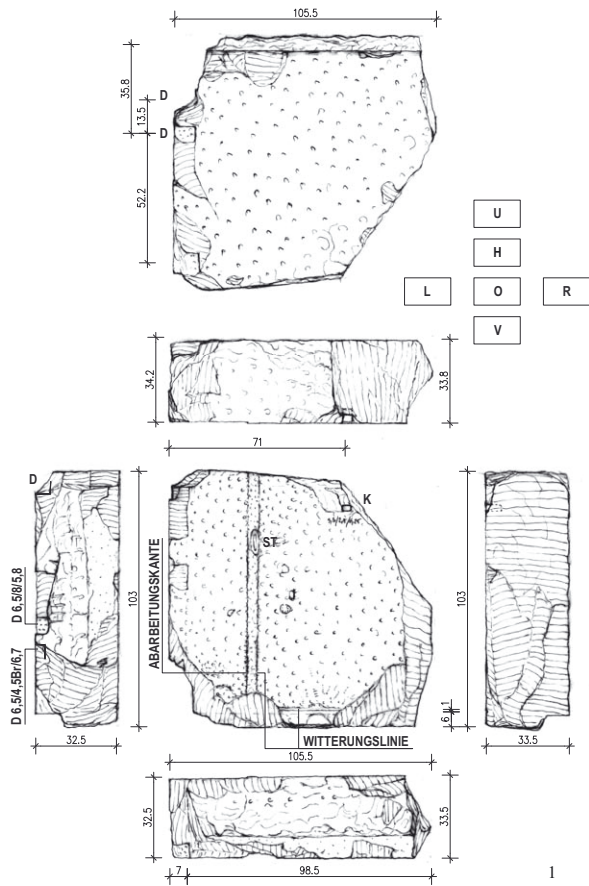

3



4



8

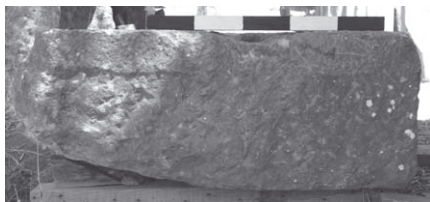

6



9



10



5

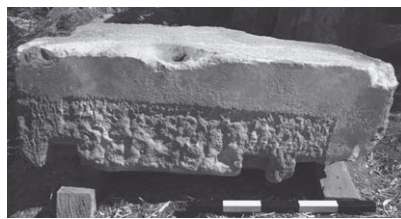

7

1-7: Stylobatblöcke der Peristasis, Schicht 21, Westseite vor der Felsbank; 2. Säule von Süden; 1: B02/1431, M = 1 : 20; 2: B02/573, M = 1 : 20; 3: Architekturprobe B02/1431 - B02/573, O; 4: B02/1431 - B02/573, V; 5: B02/1431, L; 6: B02/573, H; 7: B02/573, L; 8-10: Bodenplattenfragmente, vermutlich vom Pteron; 8: B02/1307, O; 9: B03/1616, H1; 10: B03/1616, O.

TAFEL 48

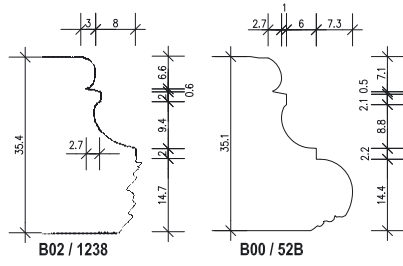
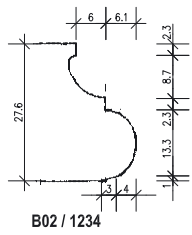

1

4

5

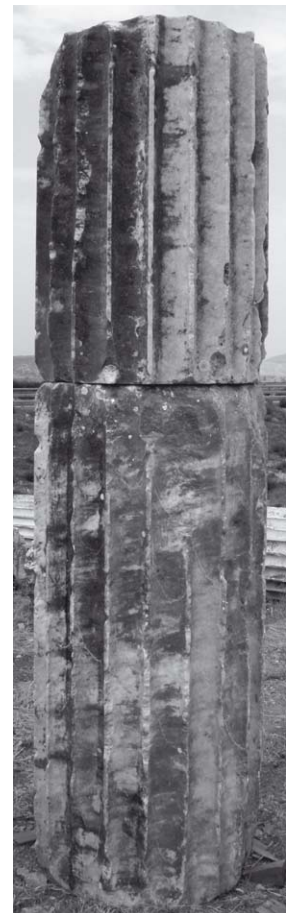
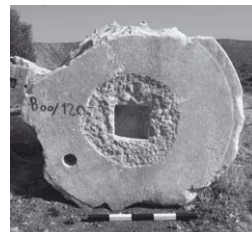
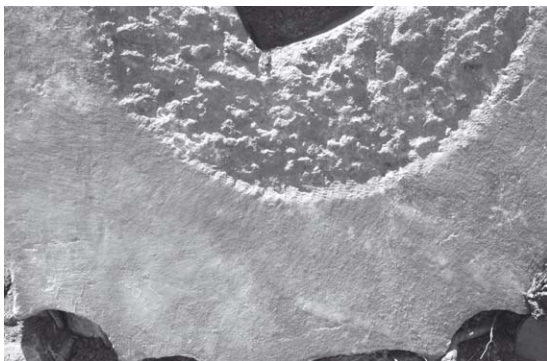
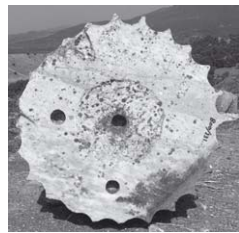

9

12

13

1–5: Basen der Peristasissäulen, Schicht P24; 1: Profile M = 1 : 10; 2–3: B02/978 Basistyp ohne oberen Torus, V, O; 4–5: B02/1235, Basistyp mit oberem Torus, Ausschnitt O mit RL, O/V;
 6–8: Mittlere Trommeln der Peristasissäulen, Schichten P26-P28; 6: B00/132, O; 7: B00/131, O; 8: B01/345, O mit originaler Reparaturklammer;
 9: B03/1470 Trommel einer Peristasissäule mit RL auf Lagerfläche;
 10–12: B00/119+120 untere Trommel mit 20 Kanneluren, 10: O, 11: Ansicht, 12: U;
 13: Architekturprobe B00/130 – B00/126, mittlere Trommeln mit 20 Kanneluren.

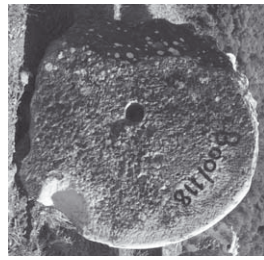
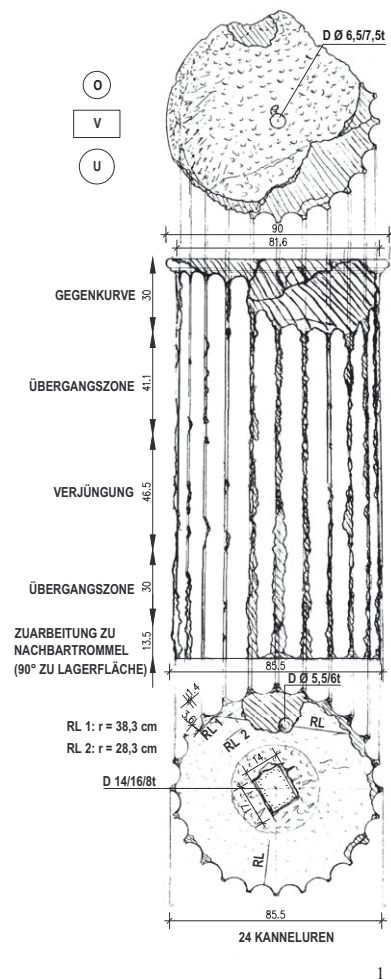

2

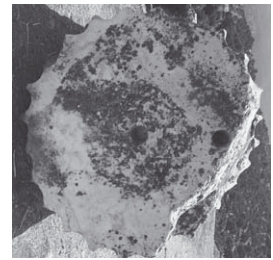

5



3



6

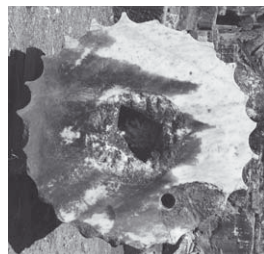

4

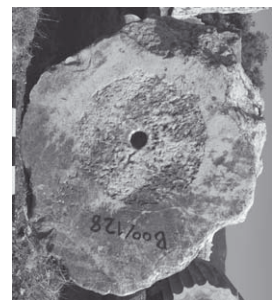

7

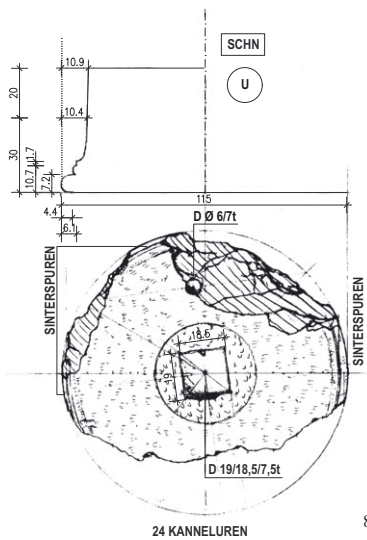

9



10

1-4: B00/118 obere Trommel einer Peristasissäule, Schicht P29; 1: O, Ansicht, U, M=1:20; 2: O; 3: Ansicht; 4: U; 5-7: B00/128 untere Trommel einer Peristasissäule, Schicht P25; 5: O; 6: Ansicht; 7: U; 8-10: B01/193 untere Trommel einer Peristasissäule, Schicht P25; 8: U und Profil mit angearbeitetem oberen Basistorus, M = 1 : 20; 9: Ansicht; 10: Architekturprobe mit B01/200.

TAFEL 50

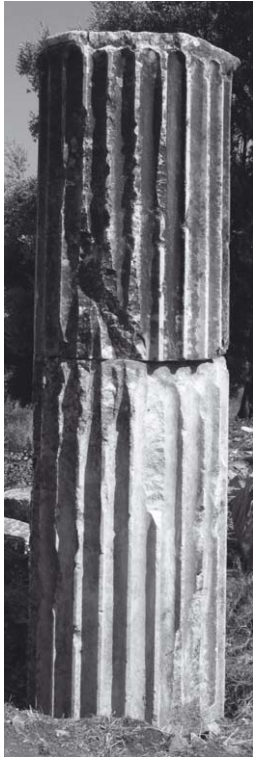

1

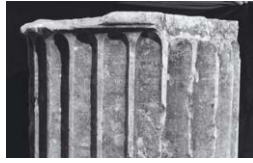

4

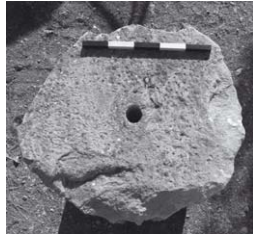

5



7

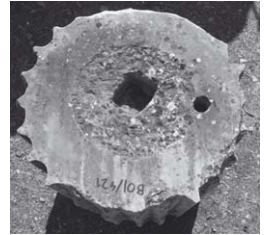

9



6

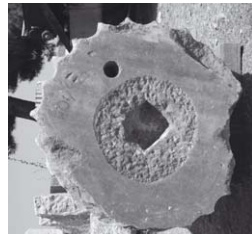

8



10



2



3



11



13

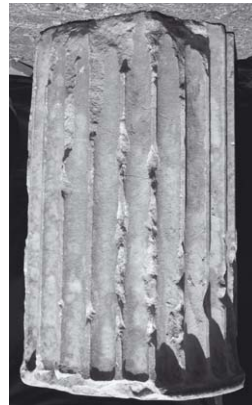

12



14

1-3: Architekturproben Säule B;
 1: Trommel 1 (B01/422 obere Tr.) und Trommel 2 (B01/424);
 2: Trommel 3 (B01/421) und Trommel 4 (B01/430);
 3: Trommel 4 (B01/430) und Trommel 5 (B01/509 untere Tr.);
 4-6: B01/422 obere Trommel, Schicht P29, Teilansicht, O, U;
 7-8: B01/424 zweite Trommel, Schicht P28, O, U;
 9-10: B01/421 dritte Trommel, Schicht P27, O, U;
 11: B01/430 vierte Trommel, Schicht P26, U;
 12-14: B01/509 untere Trommel, Schicht P25, Ansicht, O, U.



1



2



3



4

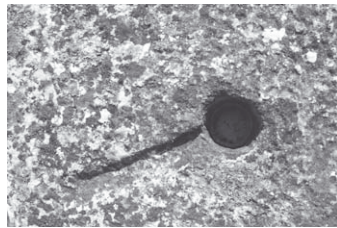

5

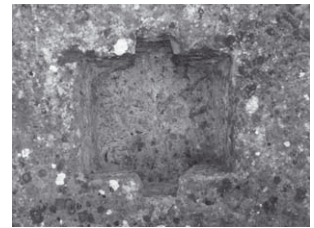

6



7



8



9



10

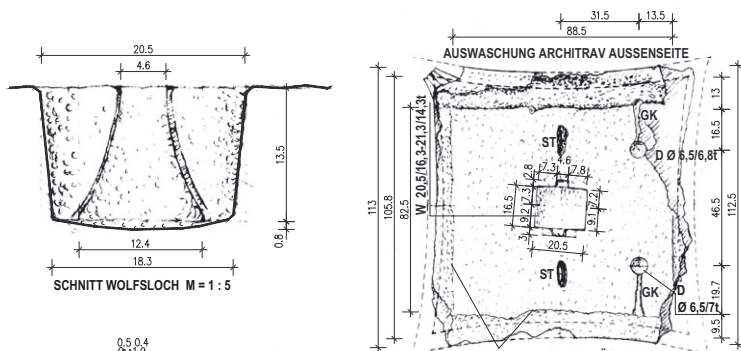

1–5: B01/473 unvollendetes Peristasiskapitell, Schicht P30;
 1: Seitenfläche; 2: O; 3: Ansicht; 4: Wolfsloch Schmalseite;
 5: O, Dübelloch mit Gusskanal;
 6–11: B01/474 Peristasiskapitell, Schicht P30; 6: Wolfsloch
 Draufsicht; 7: L; 8: V; 9: R; 10: H; 11: Schnitt Wolfsloch
 M = 1 : 5, O, R, H, vervollständigte Ansicht, jeweils M = 1 : 20.

DETAIL	O	VERVOLLST. ANSICHT
R	H	



VERVOLLSTÄNDIGTE ANSICHT 11

TAFEL 52



1



2



3



4



5

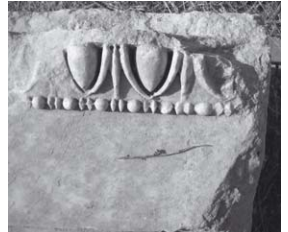

7



6



8

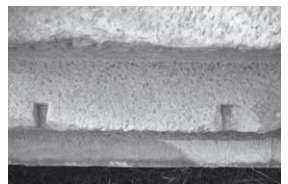

11



9

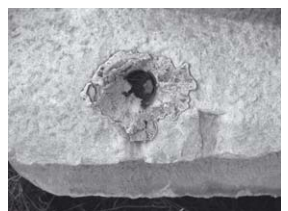

12



10

1-4: Oberflächenstruktur und Abwitterungen auf den Kanneluren der Peristasisäulen;
 5-8: B01/337 Peristasisarchitrav, Südseite Mitteljoch; 5: V/U; 6: O; 7: Eierstab, rechtes Ende;
 8: Eierstab, linkes Ende;
 9-12: B01/341 Peristasisarchitrav, Südseite; 9: V; 10: O; 11: Vierungsausnehmung mit
 Schwalbenschwanz-Klammerlöchern; 12: Dübelloch mit Bleifüllung, daneben
 Vierungsausnehmung mit Schwalbenschwanz-Klammerloch.



1



4

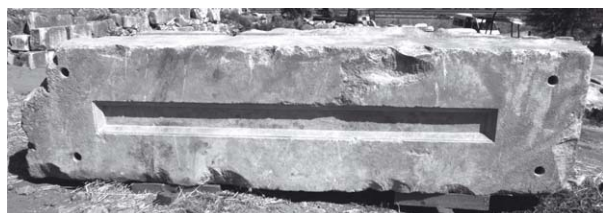

2

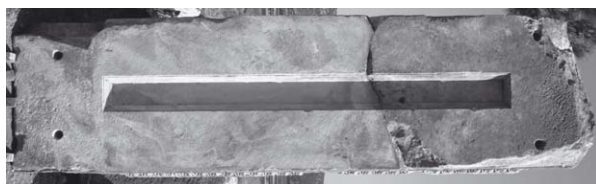

5



3



6



7

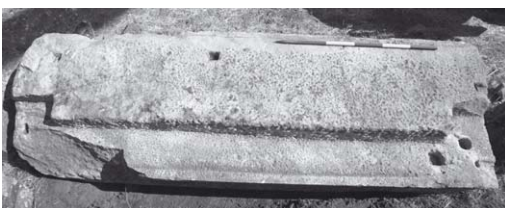

8



9

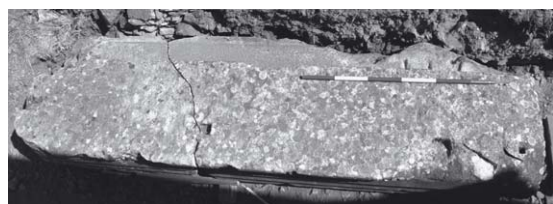

10



11



12

1–3: B01/326 Peristasisarchitrav, Südseite; 1: O; 2: U; 3: Ausschnitt H mit Vierungsausnehmungen;
 4–5: B02/804+859 Peristasisarchitrav, Westseite; 4: V; 5: U;
 6–9: B01/566 Peristasisarchitrav, Westseite, Mitteljoch; 6: V mit Anthemienfriesblöcken B02/964 und
 B02/646; 7: L/V; 8: O; 9: H/L;
 10–11: B01/539+540 Peristasisarchitrav, Westseite / Südwestecke; 10: O; 11: Ausschnitt O mit Innenecke;
 12: Architekturprobe Südwestecke, Westseite, Architrav B01/539+540, Anthemienfriesblöcke B02/1046
 und Eckblock B02/647, Gesimsblock B02/622, Dachskulptursockel B02/773.



1



2

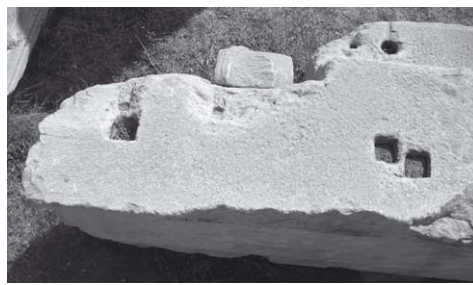

3



4

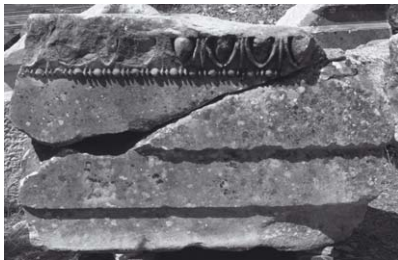

5



6

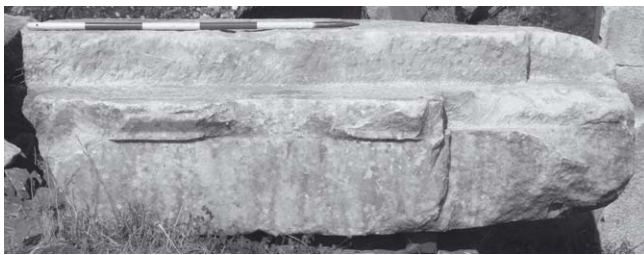

7

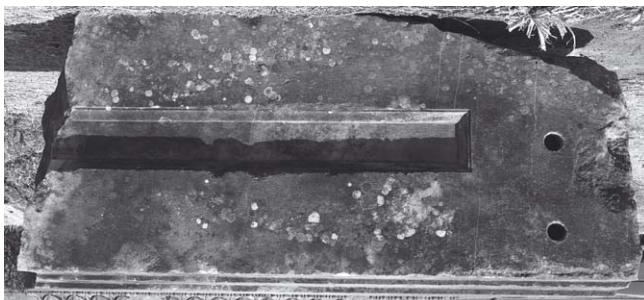

8



9

1-4: TH214 Peristasisarchitrav, Ostseite / Südostecke, (dep. auf Agora von Izmir); 1: V_{OST}; 2: V_{SÜD}; 3: O Ausschnitt Eckbereich; 4: O/R; 5-6: B02/800+1185 Peristasisarchitravbruchstück, Nordostecke; 5: V_{NORD}; 6: O; 7-8: B00/109 Peristasisarchitravbruchstück; 7: H; 8: U; 9: B00/111+112+B03/1453 Peristasisarchitravbruchstück, U/V.

TAFEL 56



1

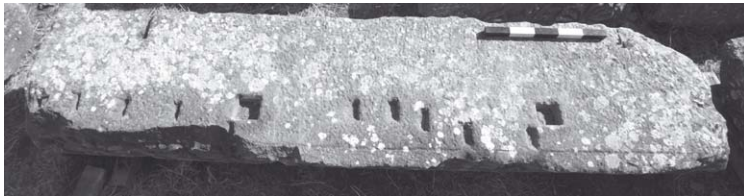

2



3



8



9

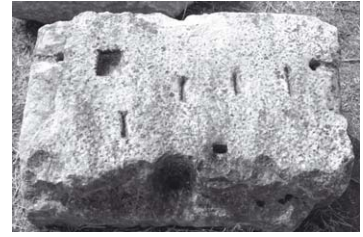

4



5

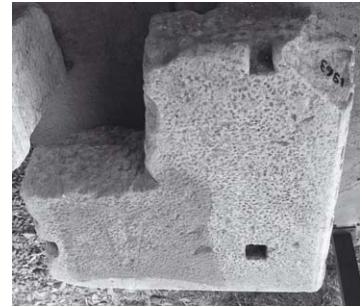

6

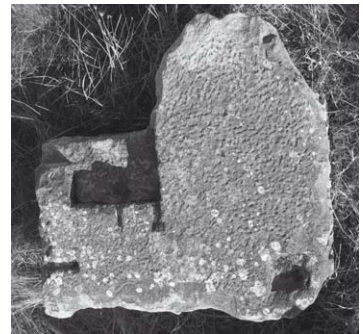

7



10

1-3: B02/964 Anthemienfriesblock Westseite über B01/566 Peristasisarchitrav, Mitteljoch; 1: V/L; 2: O; 3: O/H;
 4: B02/633 Anthemienfriesblock O/H mit Klammernische;
 5-6: Anthemienfriesblock der Südostecke, Inv.nr. 1963, Acik-Hava-Depot, Ephesos; 5: R; 6: U/L;
 7: B00/66 Anthemienfriesblock der Nordostecke, O;
 8-10: B04/1623 Anthemienfriesblock der Westseite, Schlussblock; 8: O; 9: V; 10: R.



1



2



3



4



5

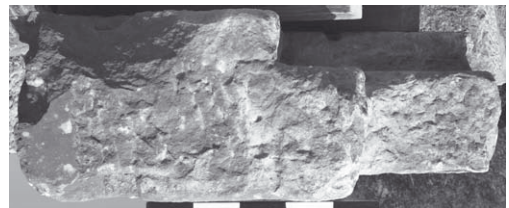

6

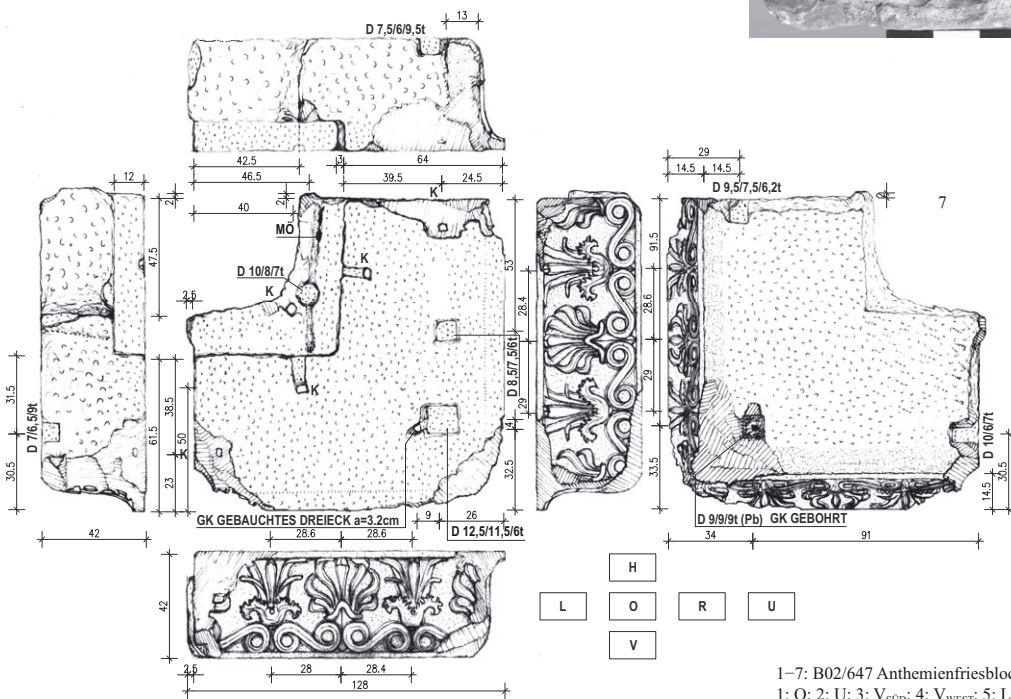

1-7: B02/647 Anthemiefriesblock der Südwestecke, Schicht P32, 1: O; 2: U; 3: V_{SUD}; 4: V_{WEST}; 5: L; 6: R; 7: M = 1 : 20.

TAFEL 58



1

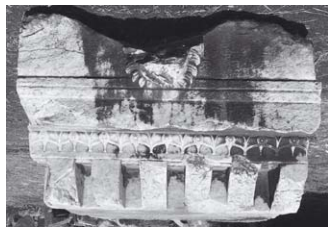

2

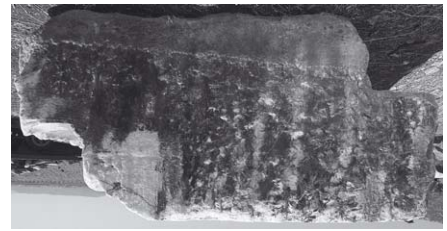

3



4



5

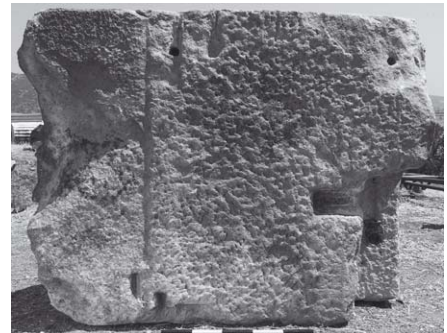

6



7



8

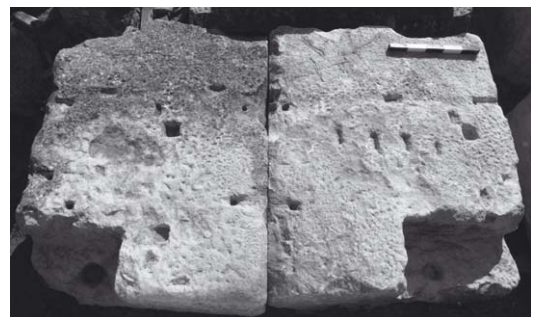

9

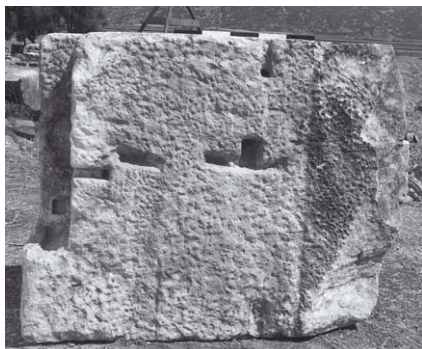

10



11

1–7: B00/102 Gesimsblock, 1: L; 2: V; 3: R; 4: U; 5: H; 6: O; 7: L/V;
 8: B01/268 Gesimsblock O;
 9: Architekturprobe Gesimsblöcke B02/619 – B02/604;
 10–11: B00/101 Gesimsblock; 1: O; 2: U.



1



6



2



7

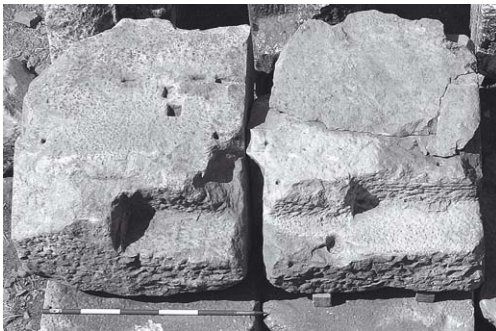

3



8



4



9



5

1–2: Architekturprobe über ganzes Joch, Gesimsblöcke B02/605 – B02/625 – B02/626+687; 1: V; 2: H/O mit vollständiger Auflagerzone für die anschließenden Kassettenblöcke;

3–4: Architekturprobe Gesimsblöcke B02/621+B03/1570 – B02/1246, O/H, H, im Block mit durchlaufendem Kassettenauflager Abarbeitung für die Kassettenblock-Stoßfugen;

5: Architekturprobe Gesimsblöcke B02/627 – B02/621+B03/1570, H, anschließend an vorhergehende Probe (3–4);

6–7: B02/599 Gesims, Eckanschlussblock; 6: R mit Stoßflächenversatz und seitlichem Dübelloch; 7: U;

8–9: Architekturprobe Gesimsblöcke B04/1621 – B03/1467; 8: O ohne Ausnehmung für Kassettenblockauflager; 9: V mit Vierungsausnehmung;

10–11: B03/1467 Gesimsblock mit Vierungsausnehmung; 10: L; 11: U.



10

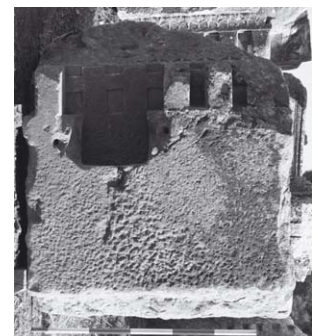

11

TAFEL 60



1



2

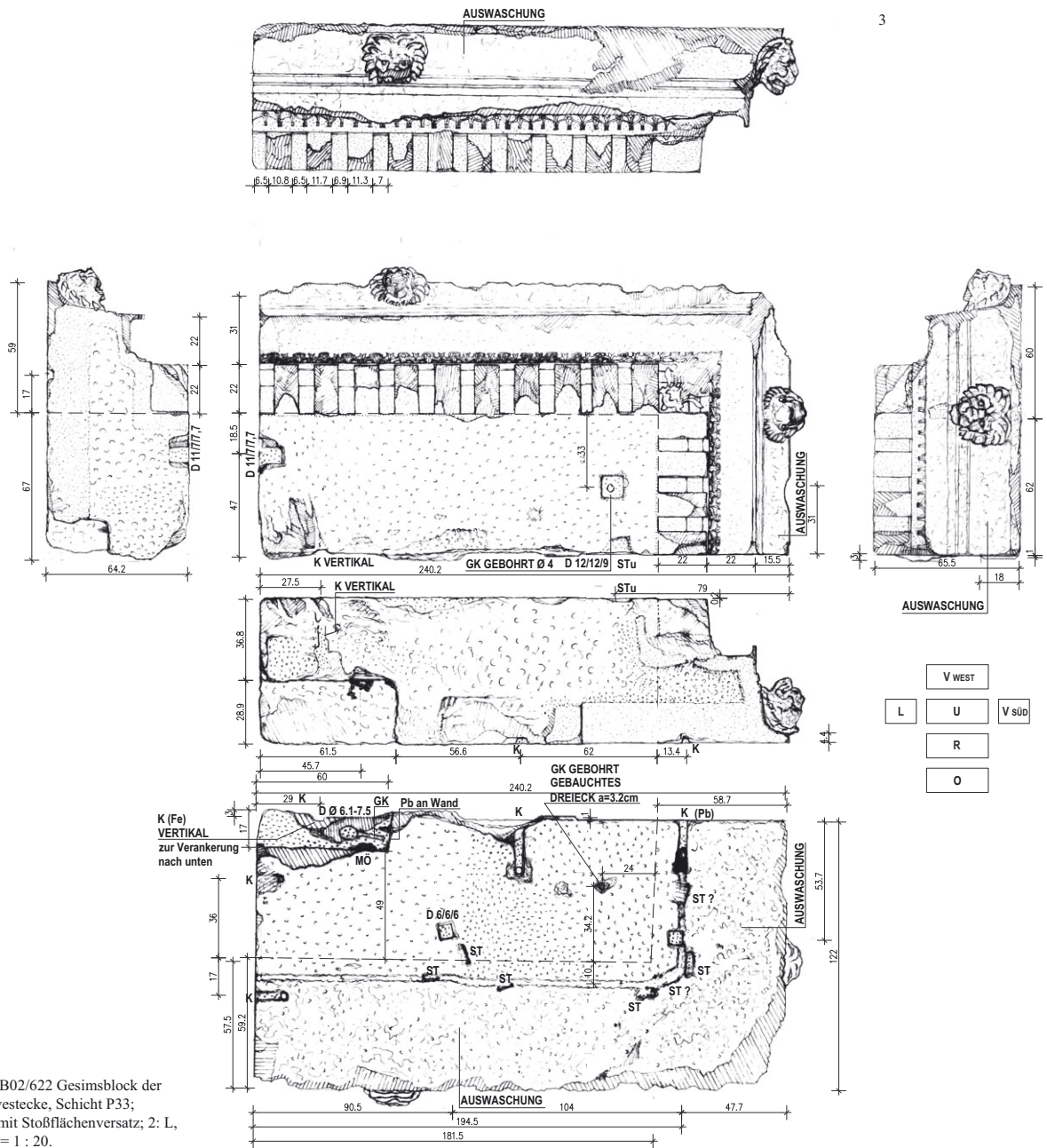

1-3: B02/622 Gesimsblock der Südwestecke, Schicht P33; 1: R mit Stoßflächenversatz; 2: L, 3: M = 1 : 20.



1



2

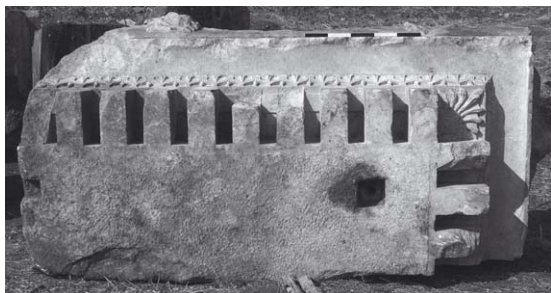

3



4



5



6



7



8



9



10



11

1-6: B00/108 Gesimsblock der Südostecke, Schicht P33; 1: V_{SÜD}; 2: R mit Stoßflächenversatz; 3: U; 4: O; 5: Detail Zahnschnittcke; 6: Detail R, Kassettenblockauflager mit Klammernische; 7-8: Architekturprobe Gesimsblöcke B02/616 – B02/603, O, H, Eckanschluss Nordwestecke mit Stoßflächenversatz auf dem Block mit durchlaufendem Kassettenauflager; 9-10: Architekturprobe Gesimsblöcke B02/611 – B02/610 – B02/616 – B02/603, O, V; 11: B02/616 Gesimsblock, R.

TAFEL 62

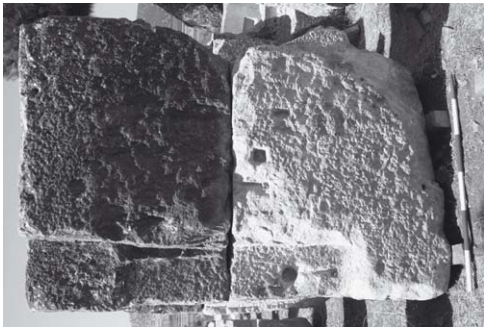

1



2



3



4



5



6



8



9



7



10

- 1: Architekturprobe Gesimsblöcke B02/594 – B02/628, Eckanschluss Südwestecke, O mit Mörtelspuren auf dem Kassettenaufleger, entlang der Kassettenblock-Stoßfugen;
 2: B02/626 Gesimsblock der Südseite, O mit Dübelloch vor den Dachskulptursockeln;
 3: B07/AG01 Gesimsblock H mit Oberflächenabarbeitungen für den Kassettenblockanschluss;
 4: Architekturprobe Architrave Westseite B01/566 – B01/543, O mit vergrößerter Auflagerausnehmung für die Kassettenquerträger;
 5–10: Architekturprobe des Peristasisgebälks der Südwestecke;
 5: Ansicht Südseite, Gesimsblöcke B02/622 – B02/624 – B02/623 über Eckfriesblock B02/647;
 6: Gesimsblöcke B02/622 – B02/624, O;
 7: Dachskulptursockel B02/773 über Gesimsblock B02/624, R;
 8: H von Dachskulptursockel B02/751 – B02/773, Gesimsblöcken B02/623 – B02/624 – B02/622 (L), Friesblöcken B02/647 (Ecke) – B02/1046 (L), Eckarchitrav B01/539+540 (O);
 9: Ausschnitt H von Dachskulptursockel B02/751 über Gesimsblock B02/623, Stemmluch auf Gesims mit korrespondierender Ausnehmung an der Unterkante des Sockelsteines;
 10: Friesblöcke B02/647 (Ecke) – B02/1046 auf Eckarchitrav B01/539+540, O.



1

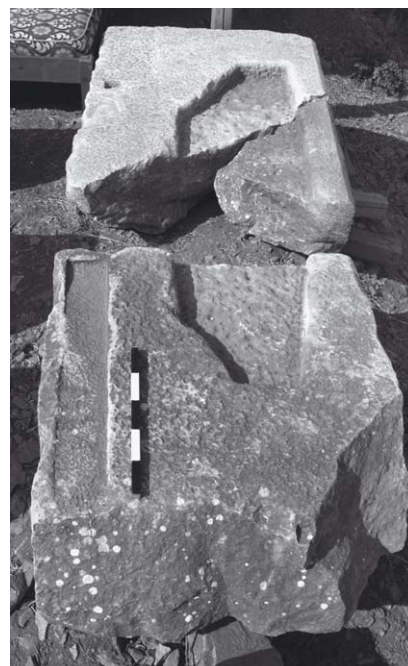

3



4



2

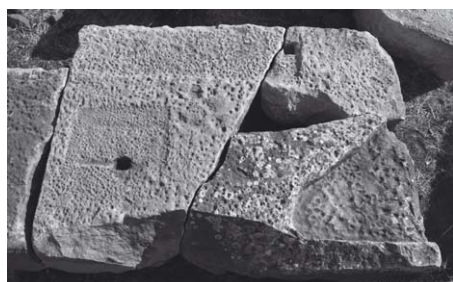

5

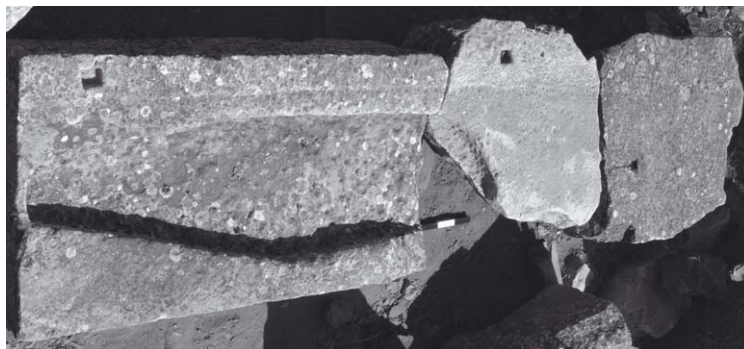

6



7



8

- 1: Architekturprobe Dachskulptursockel B02/753 – B02/758+759+760 mit ganzer Löwenplinthenausnehmung;
 2: Architekturprobe Dachskulptursockel B02/752 – B02/756 mit geringfügig eingetiefter Plinthenausnehmung;
 3: Architekturprobe Dachskulptursockel B02/1375+B03/1452 – B02/1376 mit Auflagerstreifen für Dachplatten;
 4–5: Architekturprobe Dachskulptursockel B00/76+B02/1368 – B05/1672 – B02/1317+1370+1373 östliche Nordseite; 4: V/O; 5: Ausschnitt O B02/1317+1370+1373 mit Grabvasenstandplatz und Löwenplinthenausnehmung, dahinter Dachplattenauflager mit Steinteilung;
 6: Architekturprobe Dachskulptursockel B02/1075 – B02/1002+1077 südliche Westseite, O mit ganzer Löwenplinthenausnehmung, Vasenstandplatz und Kantendübellöchern im Dachplattenlager;
 7: B02/1075 Dachskulptursockel U mit unteren Stemmlöchern;
 8: Architekturprobe Dachskulptursockel B02/755 – B02/757 – B02/766, O mit Löwenplinthenausnehmungen, Vasenstandplatz und Kantendübellöchern im Dachplattenlager.

TAFEL 64



1



2



3



4



5

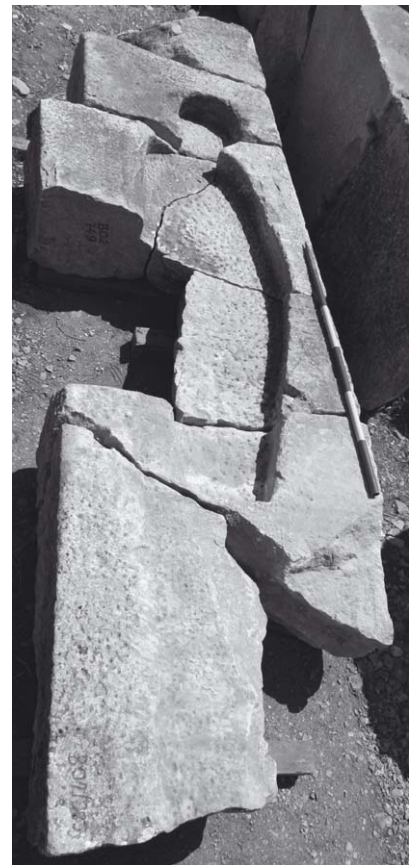

7



6



8



9



10

1–5: Architekturprobe Dachskulptursockel mit ganzer Löwenplinthenausnehmung – Gesims, nördliche Westseite B02/604 – B02/619 – B02/620 – B02/748 – B02/745A+B; 1: O/V; 2: B02/620 unter B02/745A+B. 3: B02/604 – B02/619 – B02/748 mit unteren Stemmlöchern; 4–5: untere Stemmlöcher auf B02/748, daneben Stemmlöcher auf Gesimsen B02/604 und B02/619;
6–7: Architekturprobe Dachskulptursockel, O mit ganzer Löwenplinthenausnehmung, nördliche Westseite B02/985+B03/1553 – B02/747+749 – B02/750+1180;
8–9: B02/754 Dachskulptursockel, Nordwesteckblock, L/U, O; 10: B02/1367 Dachskulptursockel, nördlicher Anschlussblock zur Nordostecke, O.

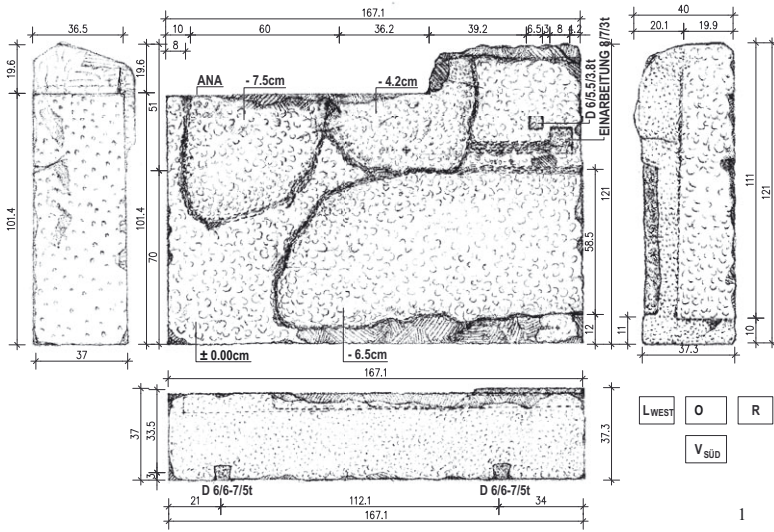

3

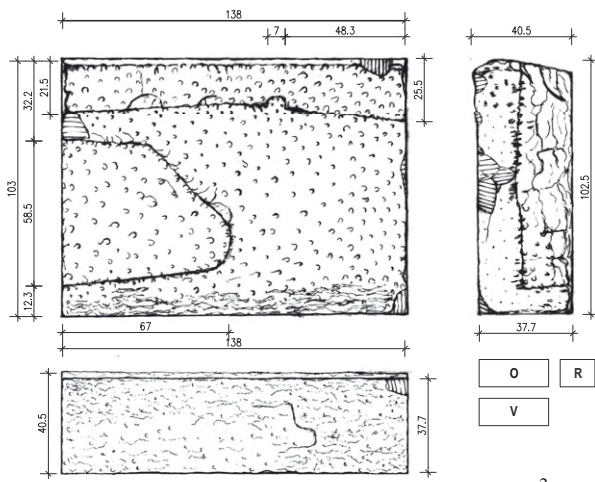

4



5



6



8



9



7

1-7: Architekturprobe Dachskulptursockel mit ganzer Pferdeplinthenausnehmung, südliche Südwestecke, 1: B02/773 Eckblock M = 1 : 20; 2: B02/751 M = 1 : 20; 3: B02/773 - B02/751, O von Osten; 4: B02/773 - B02/751, O von Nordwesten; 5: B02/773, U mit Kantendübellöchern zur Sichtseite hin; 6: B02/751, R; 7: B02/751, L.
8-9: Architekturprobe Dachskulptursockel mit Pferde- und Löwenplinthenausnehmung, nördliche Nordwestecke, B02/764+767+770 - B02/769, O.

TAFEL 66

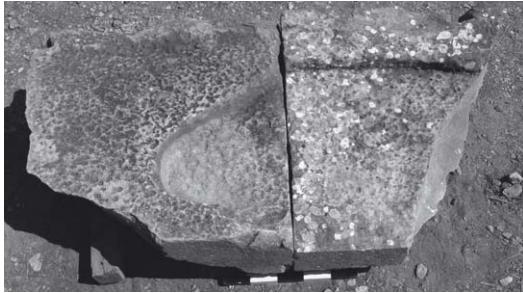

1



2



3

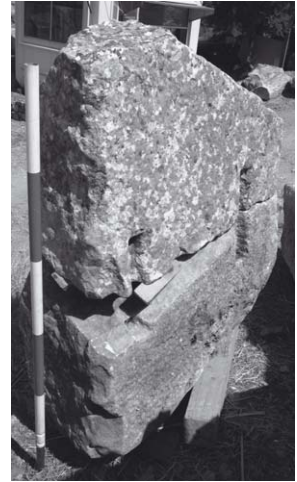

4



5

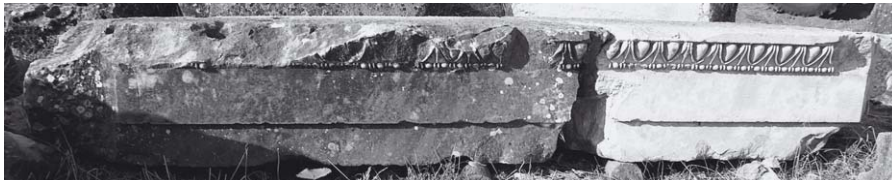

6



7

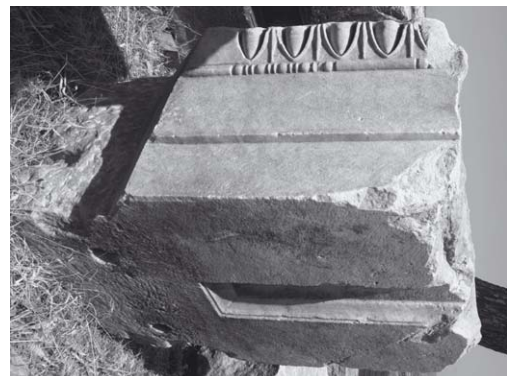

9



8

1–3: Architekturprobe Dachskulptursockel mit Löwenplinthenausnehmung und Schwalbenschwanzklammer zu hinten anschließendem Füllblock, B02/762A – B02/1369; 1: O; 2: H; 3: Detailausschnitt mit Schwalbenschwanzklammer;
 4: B03/1451 Dachskulptursockel mit doppelter Reparaturverklammerung auf der Unterseite;
 5–6: B00/123+124 ganzer Kassettenquerträger, Schicht K1, O, R (Sichtseite);
 7–8: B01/207 Kassettenquerträger, Schicht K1, mauerseitiges Bruchstück, O, L (Sichtfläche);
 9: B02/850 Kassettenquerträger, Schicht K1, kolonnadenseitiges Bruchstück mit teilweise unausgearbeitetem Astragal und Eierstab, R (Sichtfläche)/U.



1



2

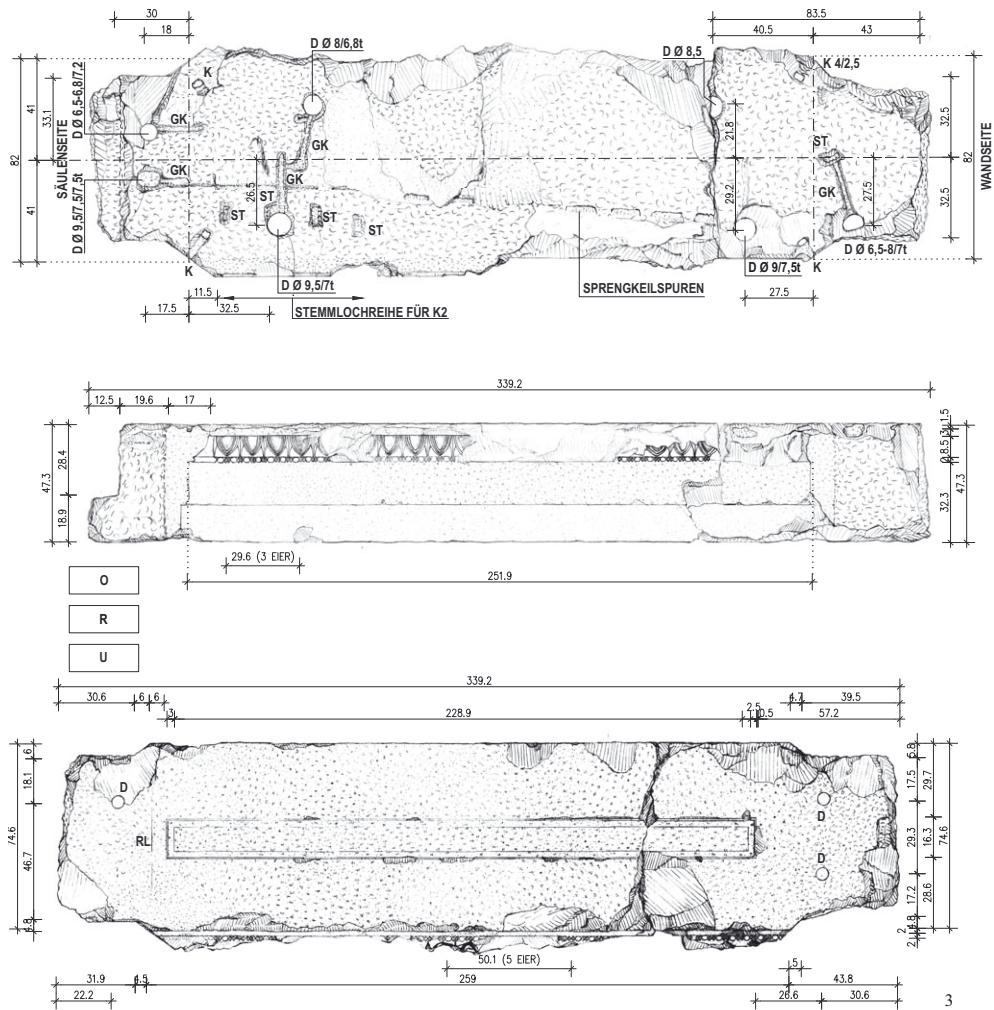

1-3: B02/666+992 ganzer Kassettenquerträger, Schicht K1, 1: L (Sichtseite); 2: U; 3: M = 1 : 20.

TAFEL 68

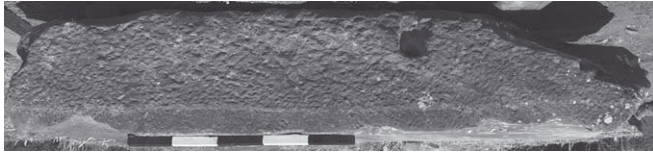

1



5



2



3



6

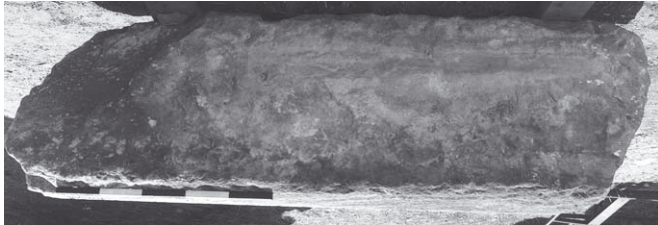

4



7



9

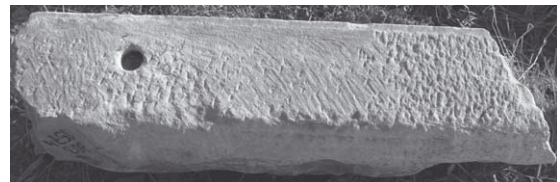

8

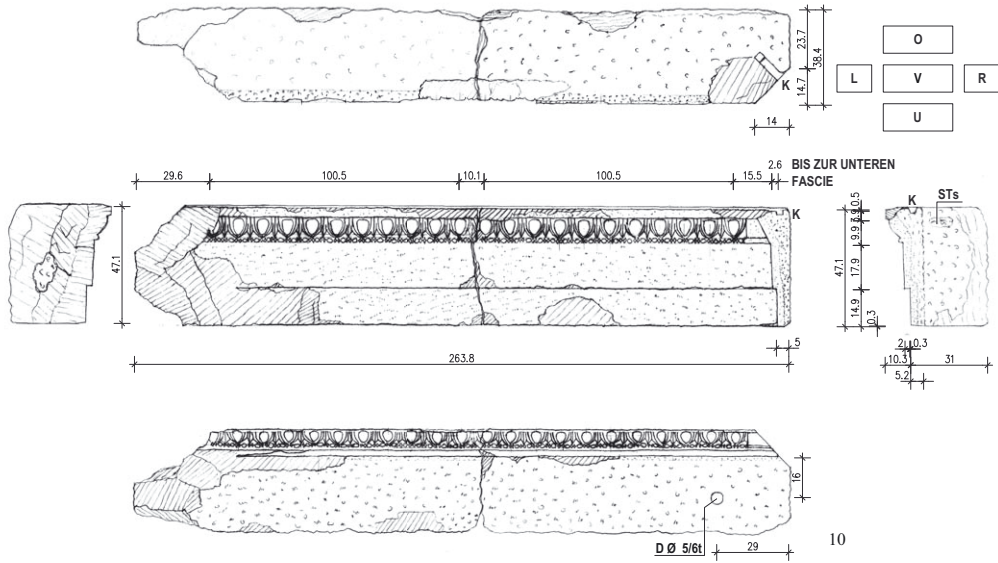

1-4: B00/44 Kassettenrahmung Schicht K1, Bruchstück mit Kantendübelloch; 1: O; 2: V/U; 3: R; 4: H;
 5: B03/1459+1460 Kassettenrahmung Schicht K1, Bruchstück von einem Eckjoch, Ecke über Ecksäule;
 6: B02/705 Kassettenrahmung Schicht K1, Bruchstück von einem Eckjoch, Ecke über Ecksäule;
 7-8: B03/1574 Kassettenrahmung Schicht K1, Bruchstück mit innenliegendem runden Dübelloch; 7: V; 8: U;
 9-10: B02/703+1196 Kassettenrahmung Schicht K1, ganzer Block; 9: V; 10: M = 1 : 20.



1



2



3



4

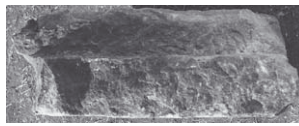

6

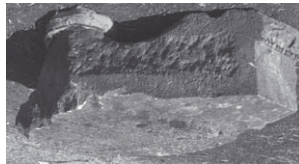

7



5

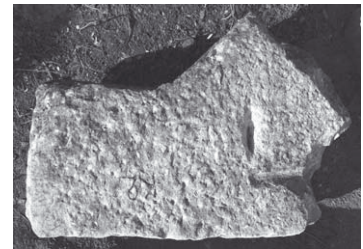

8



9

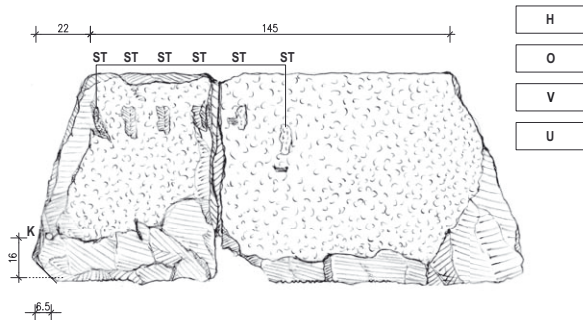

10



11



12



13

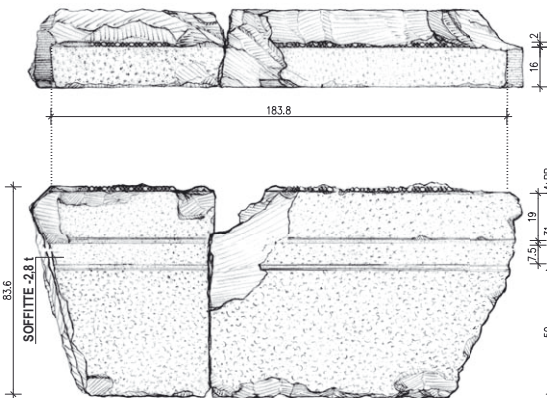

1-3: B02/741 Kassettenrahmung Schicht K2, Bruchstück; 1: O; 2: U; 3: V/R;
 4-7: B00/114 Kassettenrahmung Schicht K2, Bruchstück der Architravseite; 4: O mit rückseitiger Ausnehmung zum Anschluss an Friesblock; 5: U; 6: H mit Ausnehmung; 7: V/L/U;
 8: B02/1034 Kassettenrahmung Schicht K2, Bruchstück eines parallel zu Wand und Architrav liegenden Blocks, an Gehrung anschließender orthogonaler Annex;
 9-13: B02/1018+1033 Kassettenrahmung Schicht K2, parallel zu Wand und Architrav liegender Block mit in ganzer Länge erhaltener Sichtseite, Mitteljoch Westseite; 9: M = 1 : 20; 10: H; 11: O; 12: V; 13: U.



1



2



3



4



5



6



7



8

1–4: B02/592+593 Kassettenrahmung Schicht K3, linke Jochhälfte, Südseite; 1: O mit Abarbeitungen für die darüberliegenden Blöcke; 2: V; 3: R/U, kolonnadenseitiger Teil; 4: R/U wandseitiger Teil;
 5–7: B02/719+725 Kassettenrahmung Schicht K3, linke Jochhälfte; 5: U; 6: H; 7: O mit Abarbeitungen für die darüberliegenden Blöcke;
 8: B02/720+724 Kassettenrahmung Schicht K3, rechte Jochhälfte, U.

TAFEL 72



1



6



2



7



3

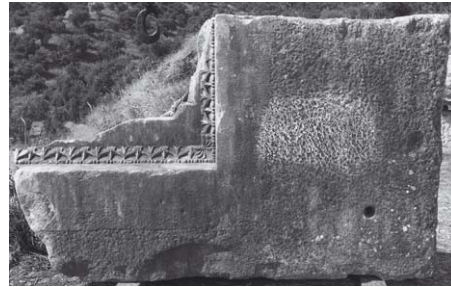

8



4



9



5

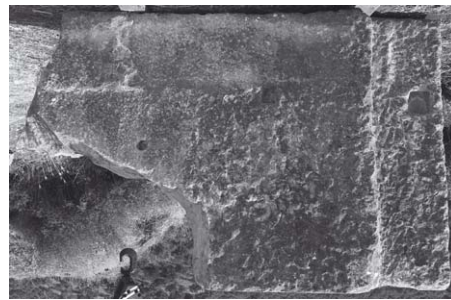

10



11



12

1-3: B00/95+B01/348+B02/1233 Kassettenrahmung Schicht K3, linke Jochhälfte mit verkürzten Schenkellängen; 1: U; 2: O/H; 3: R, kolonnadenseitiger Teil;
 4: B00/97 Kassettenrahmung Schicht K3, kolonnadenseitiger Teil, U mit rundem innenliegendem Dübelloch im Gesimsauflager;
 5: B02/679 Kassettenrahmung Schicht K3, kolonnadenseitiger Teil, U mit Kantendübelloch im Gesimsauflager;
 6: B00/94 Kassettenrahmung Schicht K3, mauerseitiger Teil mit verlängerten Schenkellängen, O mit Abarbeitungen für die darüberliegenden Dachplatten;
 7: B00/98 Kassettenrahmung Schicht K3, kolonnadenseitiger Teil mit verlängerten Schenkellängen, L;
 8-12: B00/03 Kassettenrahmung Schicht K3, mauerseitiger Teil, 8: U; 9: L; 10: O; 11: H; 12: R.



1

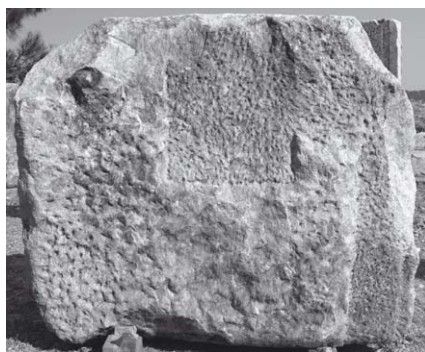

2



3



4

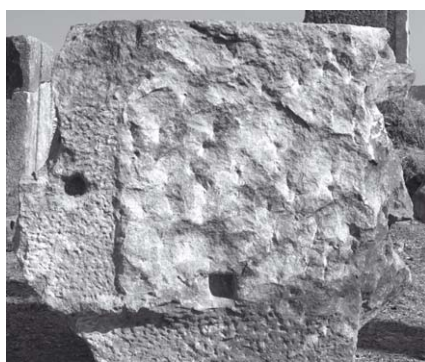

5



10



6

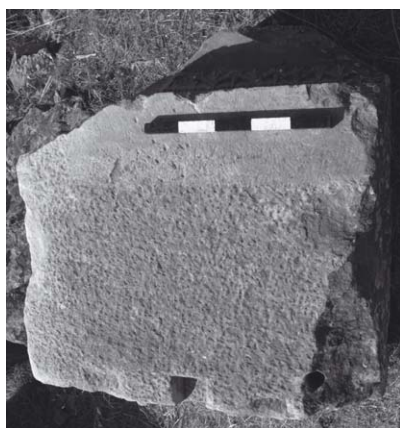

8

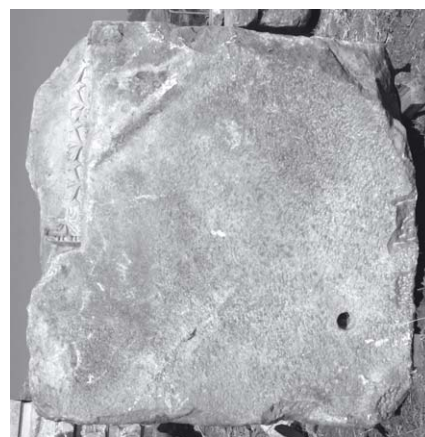

11



7



9

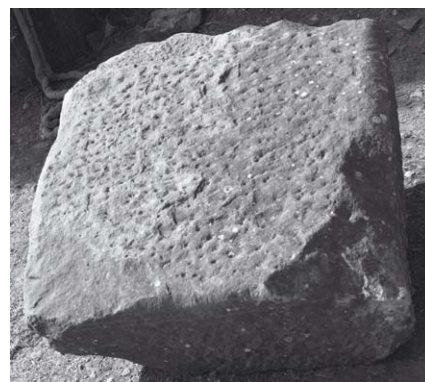

12

1–3: B02/723 Kassettenrahmung Schicht K3, kolonnadenseitiger Teil, 1: V/O; 2: O; 3: O/BR+ innere Sichtseite;
 4–5: B02/714 Kassettenrahmung Schicht K3, mauerseitiger Teil; 4: BR+ innere Sichtseite/O; 5: O;
 6: B02/1332 Kassettenrahmung Schicht K3, Ausschnitt U mit RL für die darunterliegende Kassettenrahmung;
 7–12: Kassettenrahmung Schicht K3, Bruchstücke von Eckjochen ohne hintere Ausnehmung; 7: B02/717, O/H/L; 8–9: B01/211, U, H/U mit Kantendübel und unteren
 Stemmlöchern; 10–12: B02/1306, R, U, O/H mit rundem Dübel und unteren Stemmlöchern.

TAFEL 74

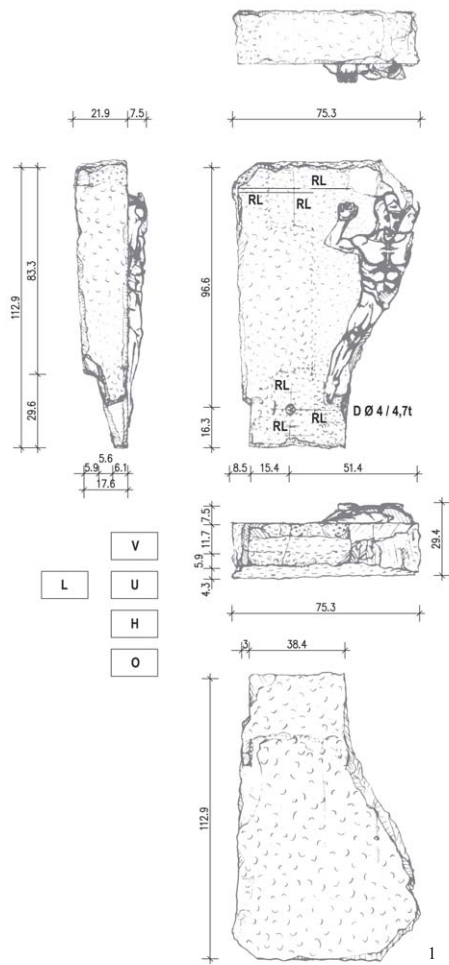

2

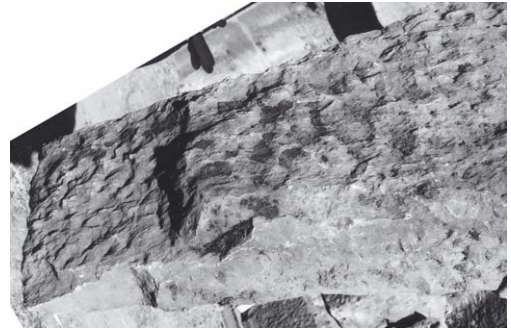

3

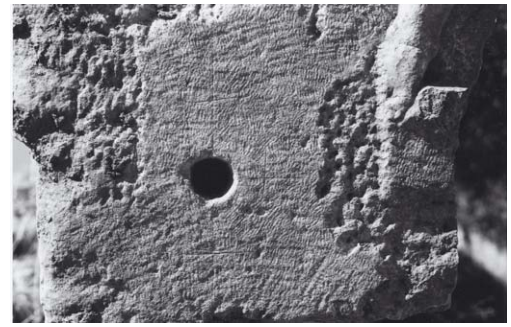

4



6

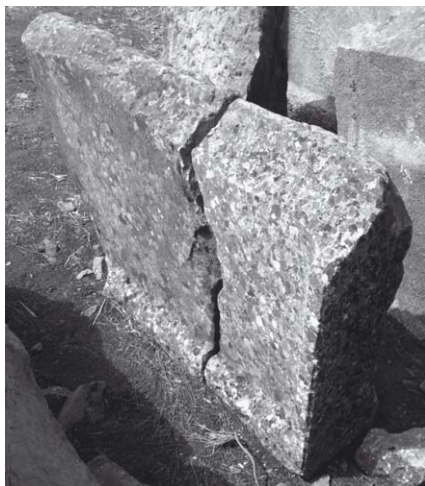

5



7



8

1–4: B03/SK28+29 Reliefplatte der Südseite, Schicht K4; 1: M = 1 : 20; 2: L; 3: Ausschnitt O/L mit abgeschrägtem Ende; 4: Ausschnitt U links unten, Auflagerbereich mit Dübelloch, rechts: linke untere Reliefecke;
 5: B02/836 Dachplatte der obersten Reihe, O/L, mit Nut an der linken oberen Stoßkante;
 6: B01/176 Dachplatte der zweiten oder dritten Reihe, Ausschnitt O mit hinterem Wulst und Abwitterungsspuren;
 7–8: seitlich hochgezogene Stege von Dachplatten mit Nut an der Außenkante und schwalbenschwanzförmigen Annexen.



1

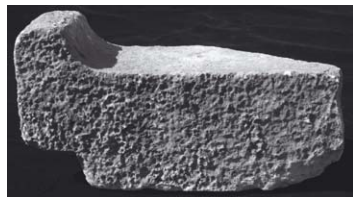

2



3



4



11

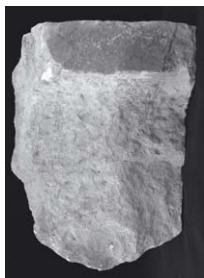

5



6



8



12

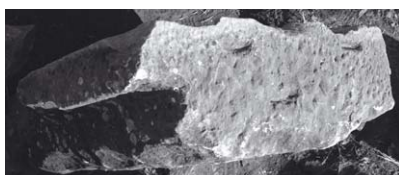

13



14

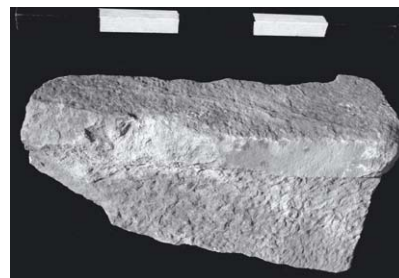

7



9



10



15

1-4: B02/1390 Dachplattenfragment, Überlappungsnase linkes Ende, untere Kante mit Hochzug; 1: O; 2: V; 3: U; 4: H (BR);
 5-6: B02/1391 Dachplattenfragment, Überlappungsnase rechtes Ende, untere Kante ohne Hochzug, U, V;
 7: Dachplattenfragment, Überlappungsnase rechtes Ende, untere Kante ohne Hochzug, U/V;
 8-10: B01/195+B02/1364 Dachplatte der obersten Reihe, Überlappungsnase linkes Ende mit Hochzug; 8: L/U/V; 9: U, 10: O;
 11-15: B02/1007 Dachplatte der obersten Reihe DP1, Ichsenanschlussblock; 11: O/V; 12: Überlappungsnase rechtes Ende ohne Hochzug; 13: R/V mit seitlichen Stemmlöchern; 14: U; 15: L/U/H.

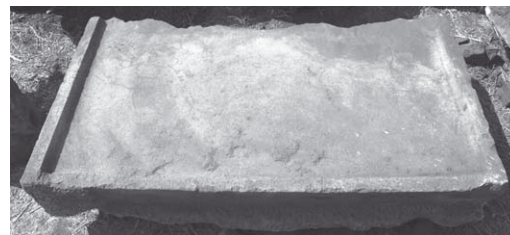
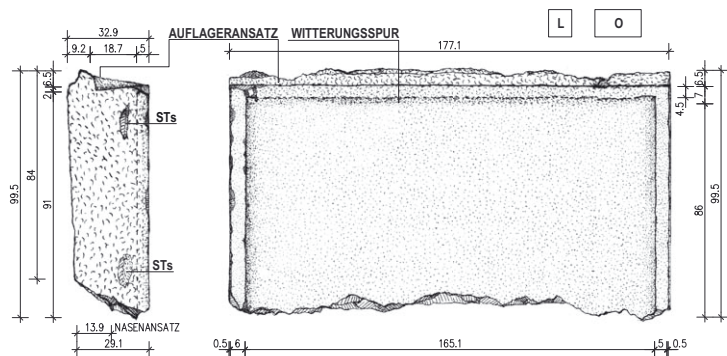

2



3



5

1-3: B03/1608 A+B Dachplatte der obersten Reihe DP1, Südseite, 1: M = 1 : 20; 2: O/H; 3: V;
4: B03/1554 Dachplatte der obersten Reihe DP1, Ichsen(Kehlen)anschlussblock, O;
5-8: B02/925 Dachplatte der obersten Reihe DP1; 5: U; 6: R; 7: O; 8: L;
9-12: B02/1360+1361 Dachplatte der obersten Reihe DP1; 9: V/U; 10: O; 11: U; 12: H.



6



7



8



4



9



10

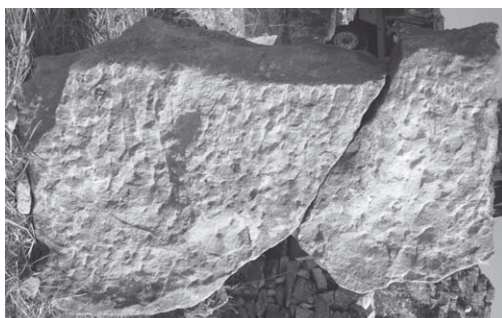

11



12

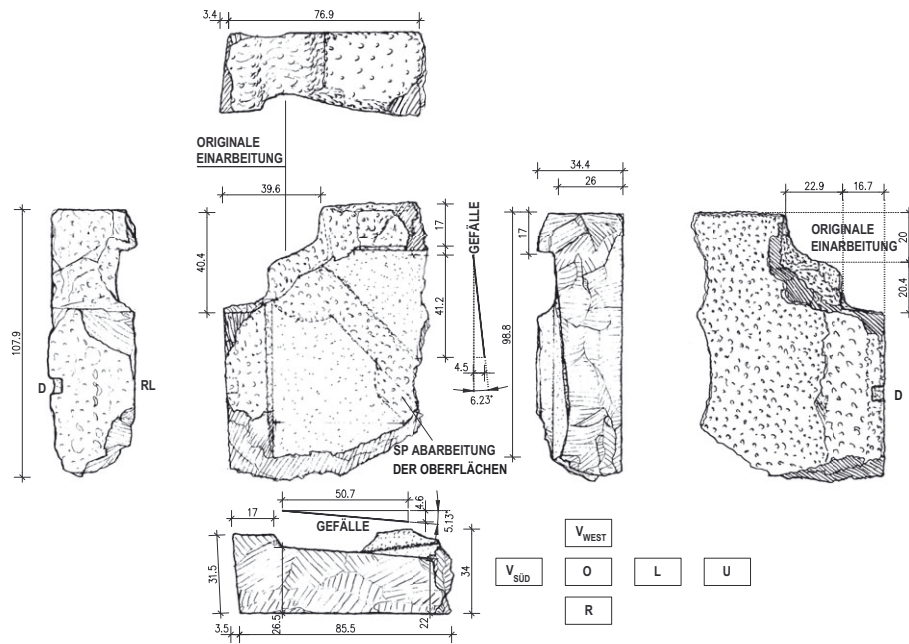

2

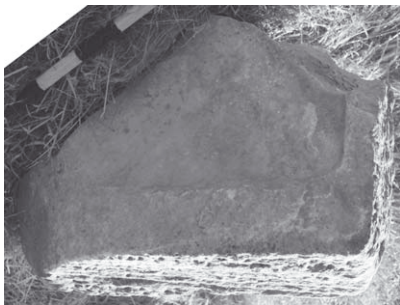

5

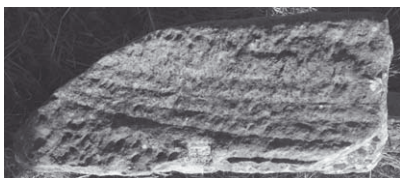

6



3



4



7

1-4: B02/910 Dachplatte der obersten Reihe DP1, Ichsenblock (Kehlenblock) Südwestecke, 1: M = 1 : 20;
 2: Sichtseite Süd; 3: O mit originalen Abarbeitungen an der Ecke; 4: U;
 5-6: B05/1681 Dachplatte der obersten Reihe DP1, Bruchstück mit Kantendübelloch an der H; 5: O; 6: H;
 7: B01/176 Dachplatte der zweiten oder dritten Reihe DP2/DP3, O.

TAFEL 82

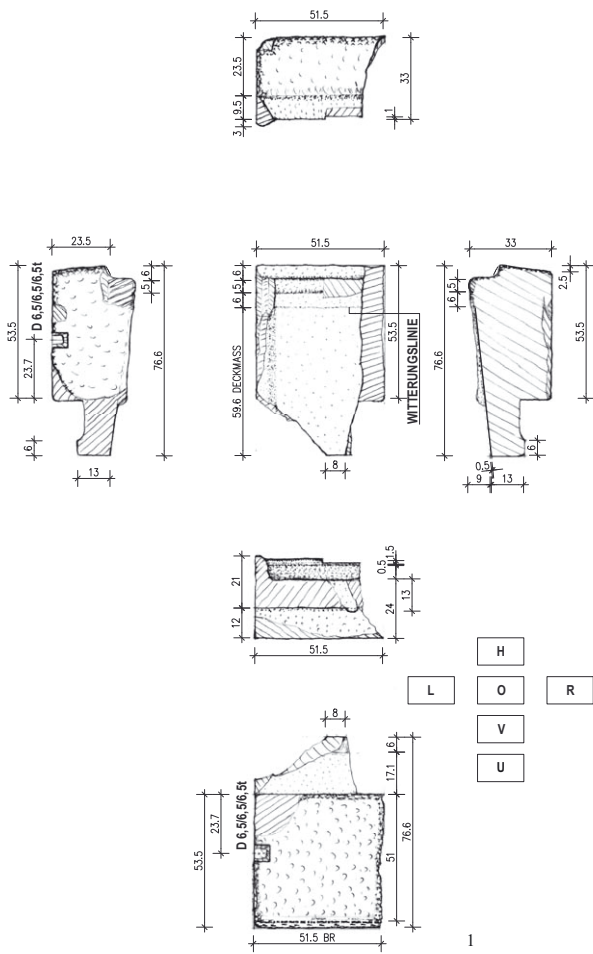

4



5

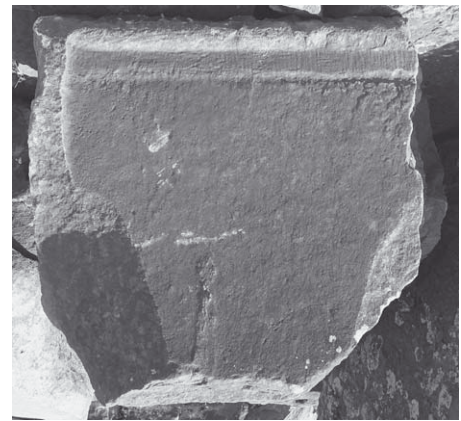

6

1-3: D1304 Dachplatte der fünften Reihe DP5, Traufplatte (W/S/O); 1: M = 1 : 20; 2: U; 3: O;
 4-5: B02/690 Dachplatte der fünften Reihe DP5, Traufplatte (W/S/O); 4: O/L mit Auflagerstreifen
 entlang der H; 5: V mit vertikaler Fläche unter der Nase;
 6-7: D1218 Dachplatte der fünften Reihe DP5, Traufplatte (W/S/O); 6: O; 7: V unter der Nase mit
 vertikaler Fläche mit Saumschlag.



2



3

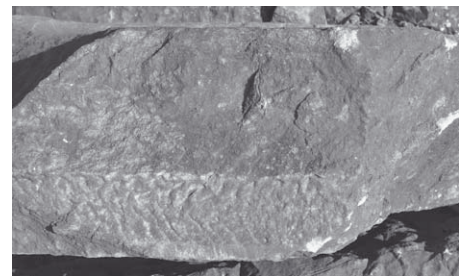

7

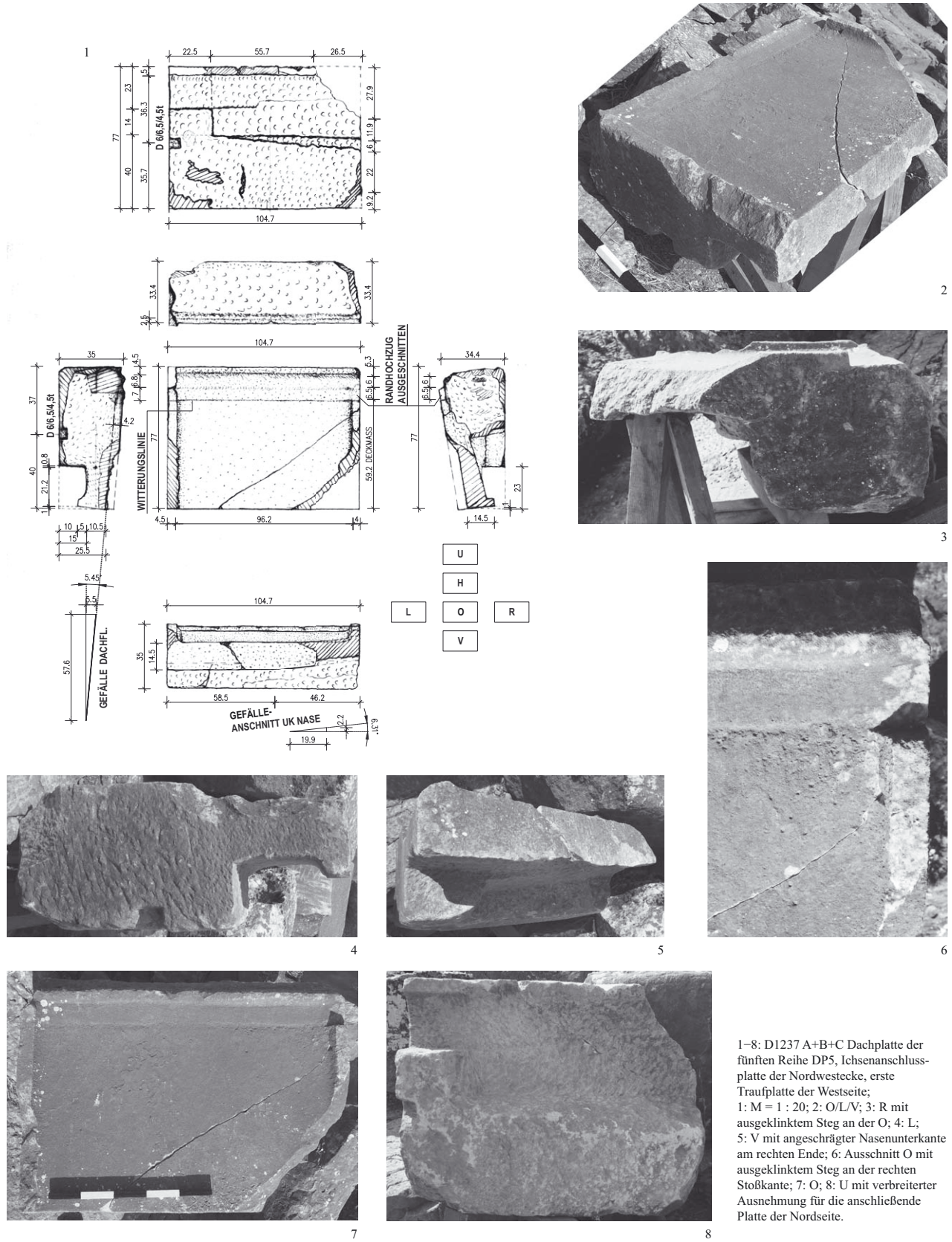

1–8: D1237 A+B+C Dachplatte der fünften Reihe DP5, Ichsenanschlussplatte der Nordwestecke, erste Traufplatte der Westseite; 1: M = 1 : 20; 2: O/L/V; 3: R mit ausgeklinktem Steg an der O; 4: L; 5: V mit angeschrägter Nasenunterkante am rechten Ende; 6: Ausschnitt O mit ausgeklinktem Steg an der rechten Stoßkante; 7: O; 8: U mit verbreiterter Ausnehmung für die anschließende Platte der Nordseite.

TAFEL 84

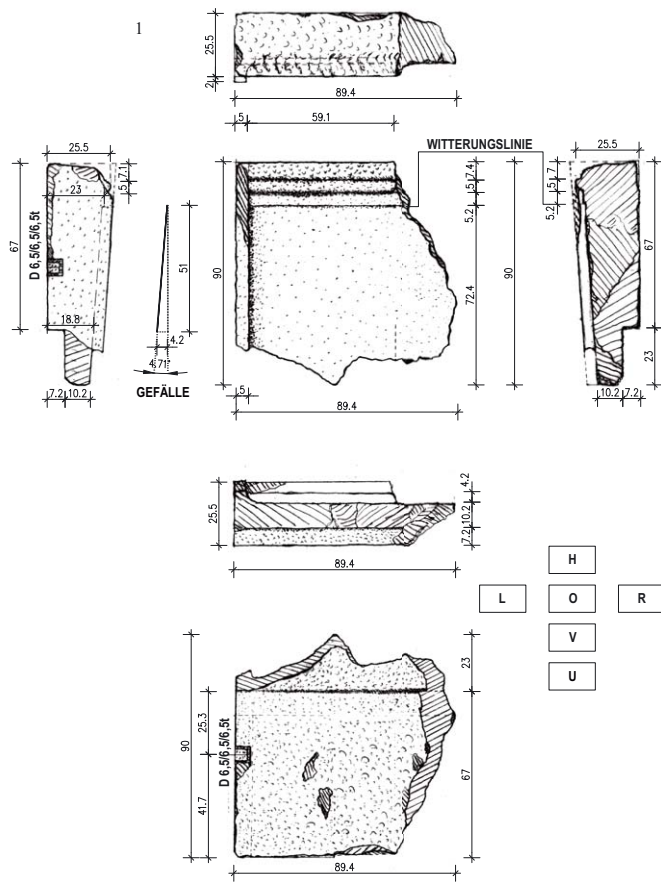

2

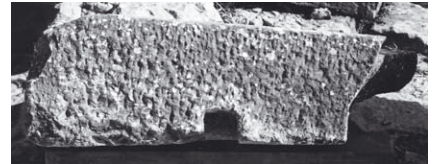

3



4



5



6



7

1-3: D1214 Dachplatte der sechsten Reihe DP6, Traufplatte der Nordseite; 1: M=1 : 20; 2: U; 3: L;
 4-5: D1207 Dachplatte der sechsten Reihe DP6, Traufplatte der Nordseite; 4: O; 5: U;
 6: Oberseite des Felssockels mit Überbauungsresten von Norden gesehen, im Vordergrund die Nordwand des Obergeschosses;
 7: Die Reste der Nordwand des Obergeschosses von Nordwesten gesehen.



1



4



5



6



2



3



7

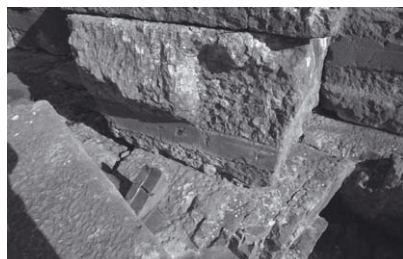

8



9



10



11



12

1: Oberseite des Felssockels mit Überbauungsresten von Süden gesehen, im Hintergrund die Nordwand des Obergeschosses, davor der Hoffußboden;
 2: Nordwestecke des Hofes von innen;
 3: Nordteil des Hofes Richtung Westen gesehen;
 4: Anathyrosis auf einem nördlichen Hofwandblock mit Abwitterungslinie auf Höhe des Fußbodenanschlusses;
 5: Hoffußbodenunterbau südlich des abgestürzten Fundamentes des nördlichen Ostwandpfeilers.
 6: Fundamentblock des mittleren Ostwandpfeilers;

7: Fundamentblock des südlichen Ostwandpfeilers *in situ*;
 8: Unterster Block des westlichen Nordwandpfeilers mit Fußbodenanschluss, Schicht 24.
 9: westlicher Nordwandpfeiler mit anschließendem Wandblock, Schicht 25, O;
 10: östlicher Nordwandpfeiler mit Fußbodenanschluss und Mauereinbindung, Schicht 24 und 25, Ostseite;
 11: Fundamentlagerfläche für den südlichen Westwandpfeiler;
 12: Felsplateau für Pteron und Südwand mit Blick Richtung Osten, links Gefällesteine des Fußbodenunterbaus *in situ*, rechts davon Fundamentplatte des westlichen Südwandpfeilers.

TAFEL 86



1



2



3



4



5



6



7



8

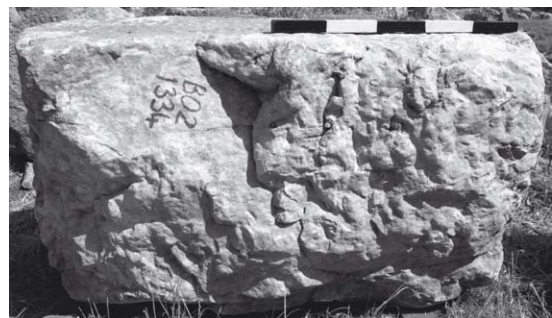

9

- 1: Fußbodenunterbau im Hof, flach geneigte Zone vor der Ostwand zwischen mittlerem und nördlichem Wandpfeiler;
 2: Fußbodenunterbau im Hof, flach geneigte Zone im Südwesten;
 3: Fußbodenunterbau im Hof, Blöcke der stark geneigten Zone im Südwesten, Blick nach Westen;
 4: Fußbodenunterbau im Hof, Blöcke der stark geneigten Zone im Südwesten, im Vordergrund das abgearbeitete Felsplateau;
 5-9: B02/1334 Hofwandblock der Nordwand / Nordostecke mit Anathyrosis für die Bodenplatten; 5: L; 6: L/V; 7: O; 8: V; 9: H.



1



2



3

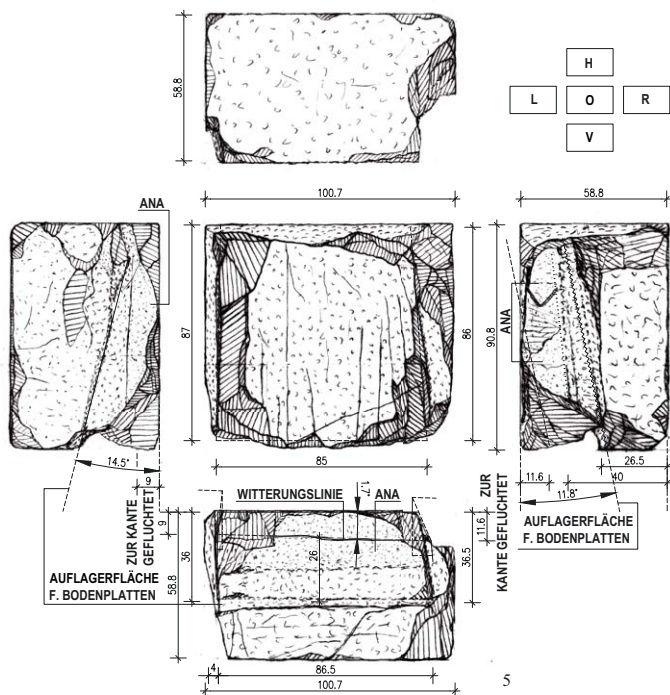

5

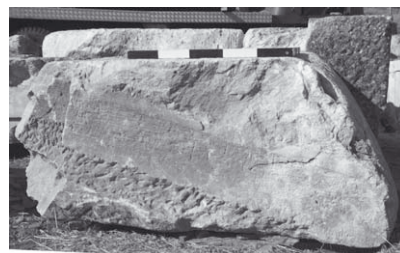

4



6

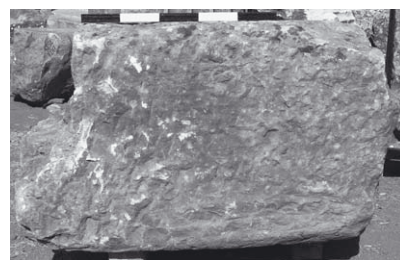

7

1-4: B02/1428 Block der Schicht 23 des südlichen Westwandpfeilers mit Fußbodenanschluss und gerundet vortretender Nordseite; 1: O; 2: R (Nord); 3: L/V/O; 4: V (Ost);
5-10: B03/1526 Block der Schicht 24 des westlichen Südwandpfeilers mit Fußbodenanschluss;
5: M = 1 : 20; 6: L/V/O; 7: H; 8: L (Ost); 9: V (Nord); 10: R (West).

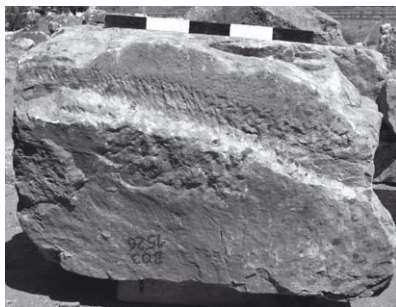

8



9

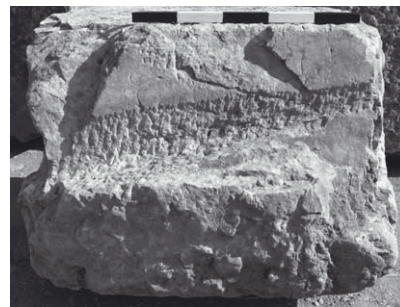

10

TAFEL 88



1

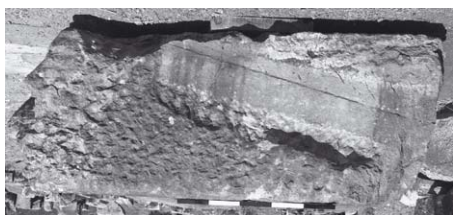

3



5



8



9

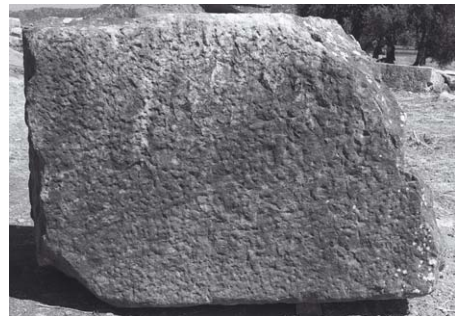

2



4



6



7

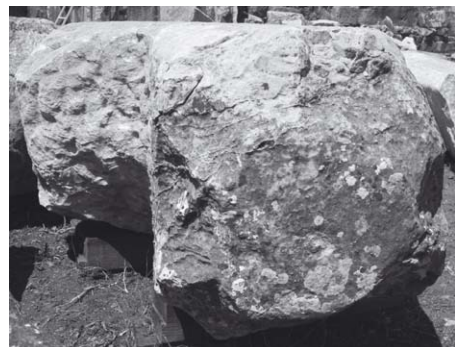

10

1–6: B00/116 Block der Schicht 25 des östlichen Südwandpfeilers mit Fußbodenanschluss; 1: O; 2: U; 3: L (Ost); 4: R (West); 5: V (Nord)/L; 6: H; 7: B02/1436 Läufer der Schicht 25 der Südwand mit Fußbodenanschluss, V; 8–10: B02/1437 Binder der Schicht 25 der Südwand mit Fußbodenanschluss; 8: O; 9: R bezogen auf innen (West); 10: V außen (Süd) mit Sichtfläche Hofwand.



1



5



2



6



3

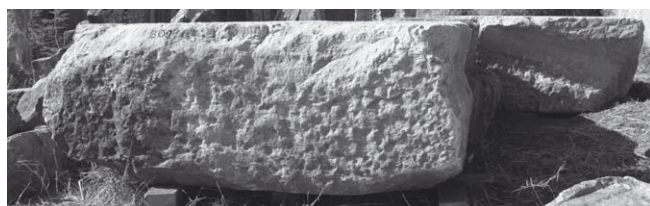

4



7

1–4: Architekturprobe Wand- und Pfeilerblöcke der Schicht 25 der Südwall, Hofinnenseite, B00/116 – B02/1436 – B02/1437; 1: O/H/R (West); 2: V/O; 3: V/L; 4: L bezogen auf innen (Ost); 5–8: B02/1278 Binder der Schicht 25 der Südwall mit Fußbodenanschluss, rechts vom Mittelpfeiler; 5: V innen (Nord); 6: V außen (Süd)/ Ost; 7: O / West; 8: M = 1 : 20.

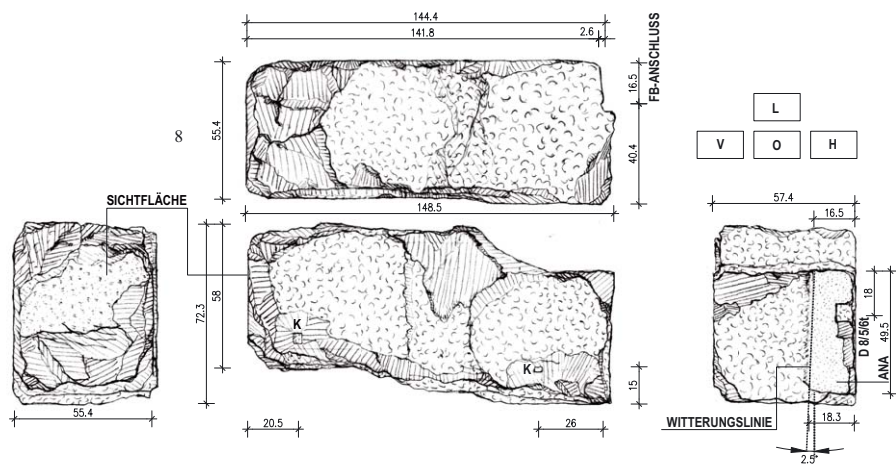

TAFEL 90



1

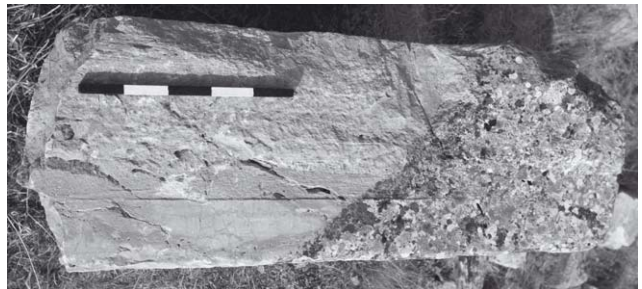

3



2



7



4



5



8

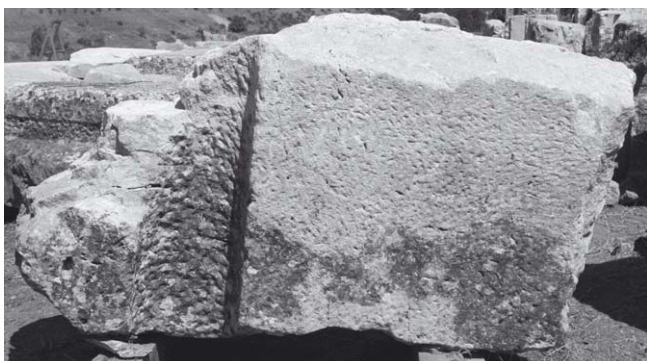

6

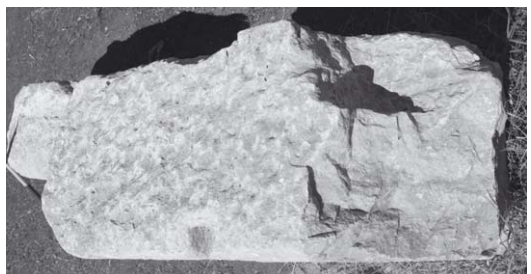

9

1–2: B00/01 Block der Schicht 25 der Ostwand mit Fußbodenanschluss, direkt an der Südostecke des Hofes; 1: O, 2: V.
 3: B03/1441 Block der Schicht 24 der Ostwand mit Fußbodenanschluss, Wandmitte, V;
 4: Abdeckung des Hofablaufes, U;
 5: B01/561 Wandblock mit rinnenartiger Einarbeitung, möglicherweise Schrotkanalrest;
 6: B01/443 Wandblock mit Wasserrinne;
 7–9: B03/1521 Wandblock mit Wasserrinne von der Hofinnenseite; 7: O; 8: V/U; 9: R.



1



2

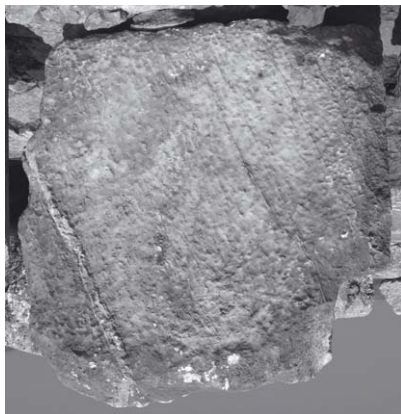

6



3



4



7



5



9

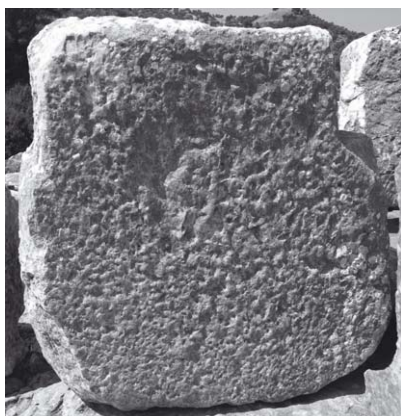

8



10

1–5: B02/669+671 oberer Abschlussblock eines Hofwandpfeilers; 1: O/V; 2: O; 3: R; 4: H; 5: U;
 6–8: D1227 oberer Abschlussblock eines Hofwandpfeilers; 6: O; 7: H; 8: U;
 9–10: D1225 oberer Abschlussblock eines Hofwandpfeilers; 9: H; 10: U/L (verkehrt liegend).

TAFEL 92

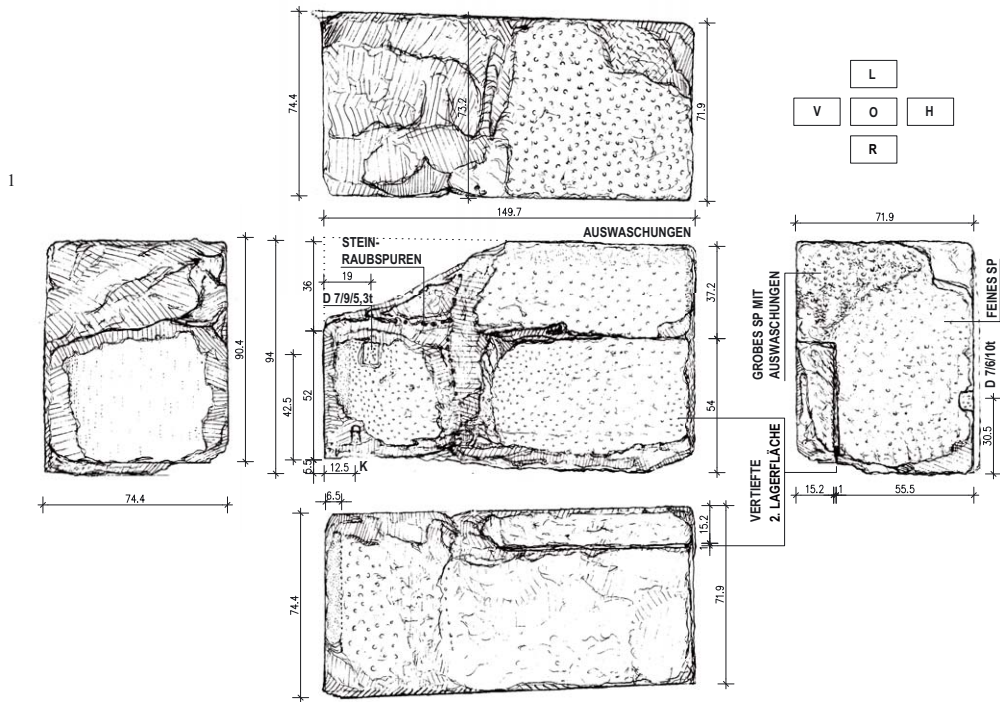

2



3



4



5



6

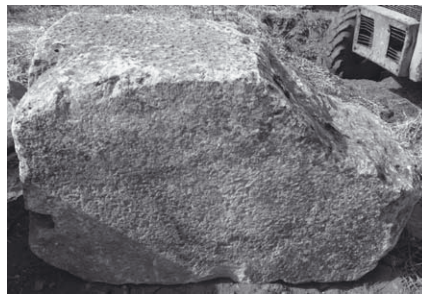

7

1-7: B01/542 Anlaufblock der westlichen Hofwand, Schicht 23, Binder hinter südlichem Westwandpfeiler;
 1: M = 1 : 20; 2: O; 3: L (Nord); 4: R (Süd),
 5: V innen = Anschlussfläche zu Pfeilerblock;
 6: V außen/O, Architekturprobe mit Anlaufblock B01/434, V; 7: U.

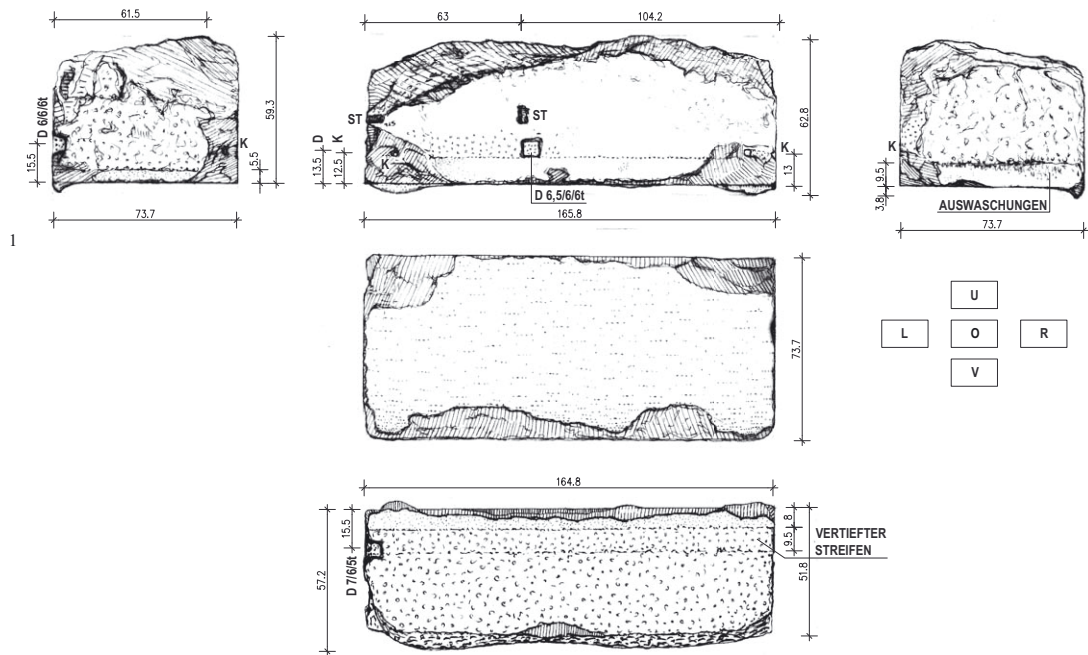

2

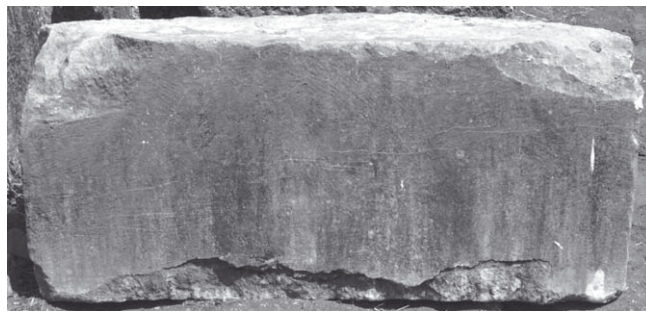

3



4



6

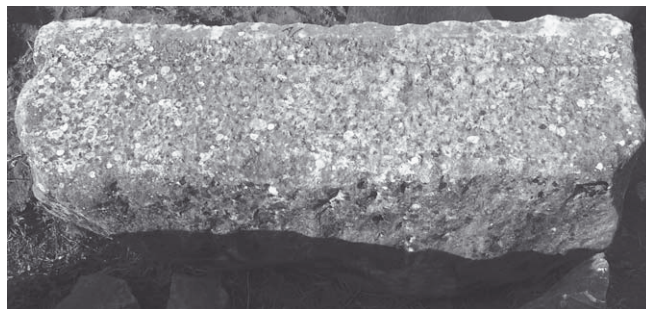

5

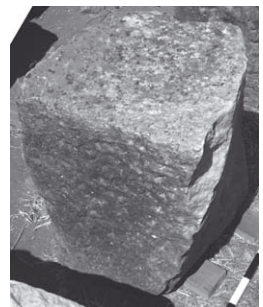

7

1-5: B01/434 Anlaufblock der westlichen Hofwand, Schicht 23, Läufer Wandaußenseite;
 1: M = 1 : 20; 2: L; 3: V; 4: R; 5: U;
 6-7: B01/467 Anlaufblock der westlichen Hofwand, Schicht 23, Wandaußenseite;
 6: V; 7: R.

TAFEL 94



1



2

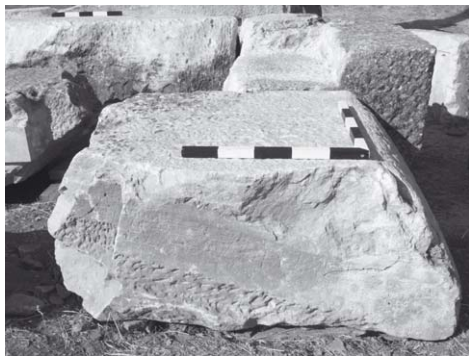

4



5



3

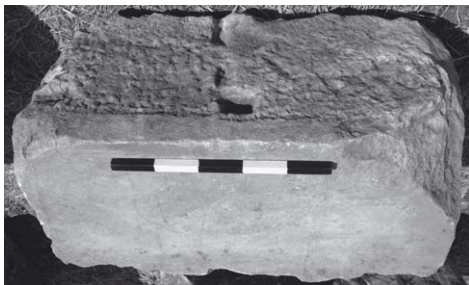

6

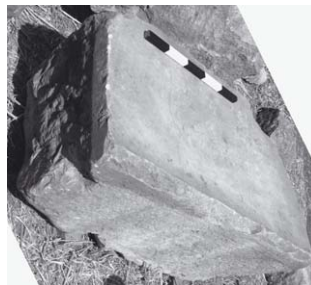

7

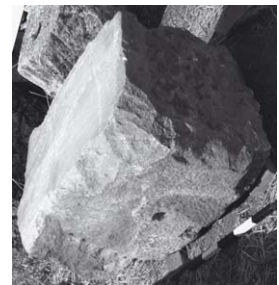

10

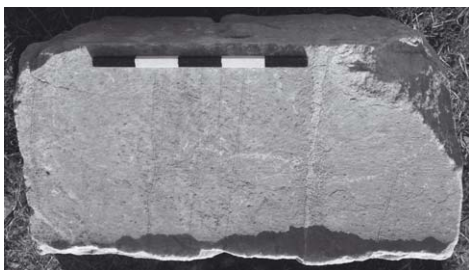

8

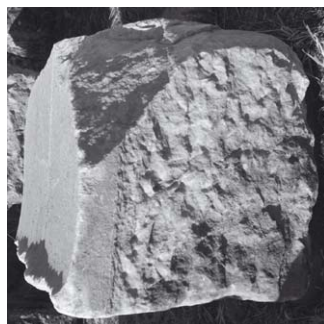

9



11

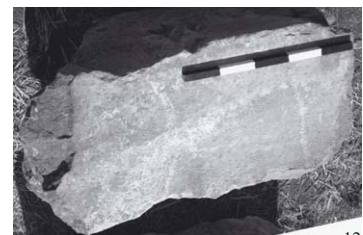

12

1–5: Architekturprobe Anlaufblöcke der westlichen Hofwand, Schicht 23, B01/542 – B01/434 mit B02/1428 Block des südlichen Westwandpfeilers;
 1: O; 2: O/R (Süd); 3: Pfeiler O/Nord; 4: Sichtseite Hof innen, Pfeiler und rechter oberer Teil des Binderblocks;
 5: Detail Sichtfläche Binderblock mit gröberer Oberfläche und Spritzspuren;
 6–9: B02/887 Anlaufblock aus dem südwestlichen Eckbereich, Schicht 23; 6: O/V; 7: L/V/U; 8: V; 9: R;
 10–12: B02/869 Anlaufblock der Südwestecke, Schicht 23; 10: V/R/U; 11: O; 12: L(BR)/V/O.

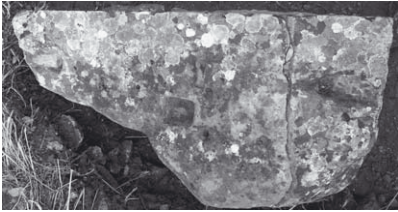

1



2

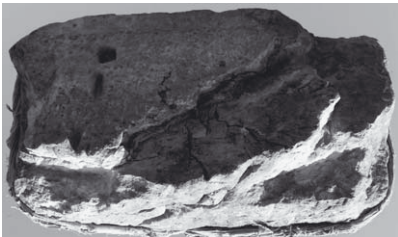

6

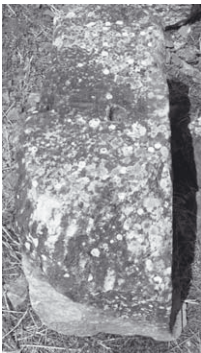

8



9

1–2: B01/469A+B Anlaufblock der Südseite, Schicht 23; 1: O; 2: O/R;
 3–7: Architekturprobe B01/475 – B01/471 Anlaufblöcke der nördlichen Hofwand, Schicht 23; 3: O/V; 4: V; 5: H; 6: B01/475 O; 7: B01/471 M = 1 : 20;
 8–9: B01/470 Anlaufblock der nördlichen Hofwand, Schicht 23; 8: O/L; 9: H.



3



4



5

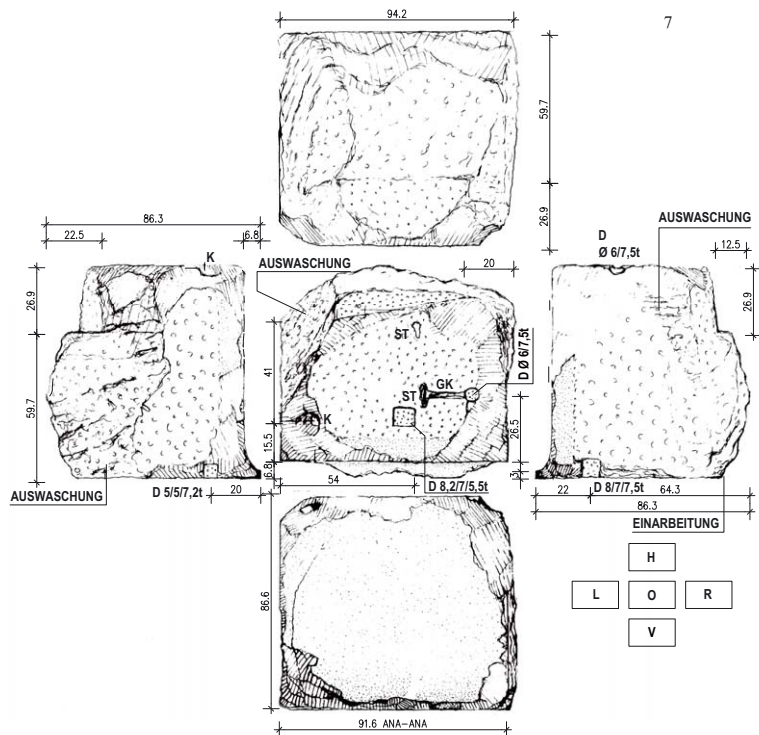

TAFEL 96

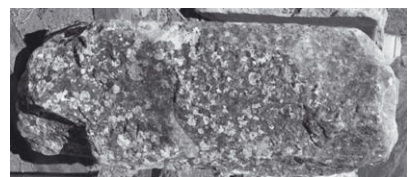
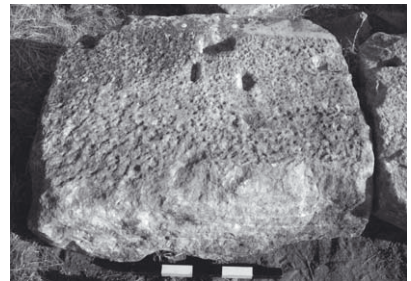
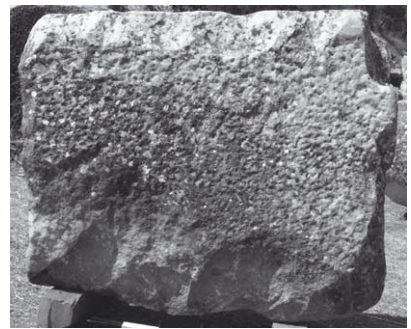
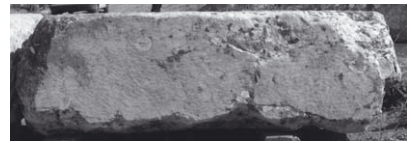
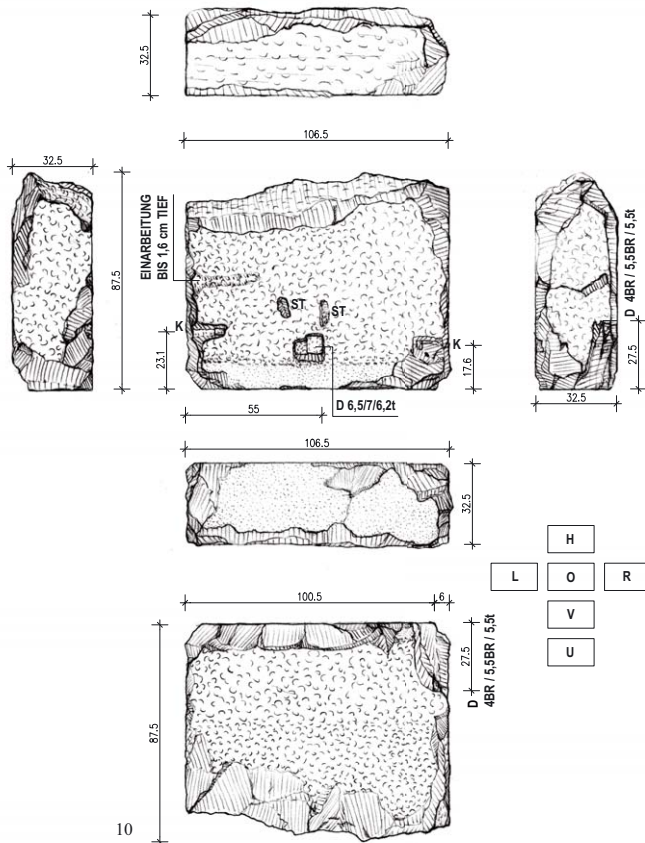
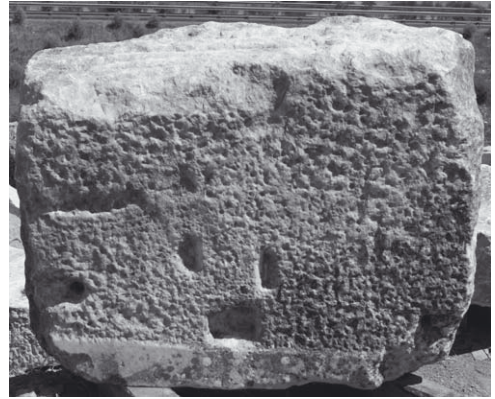
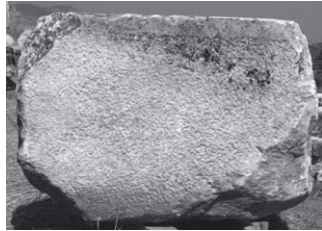
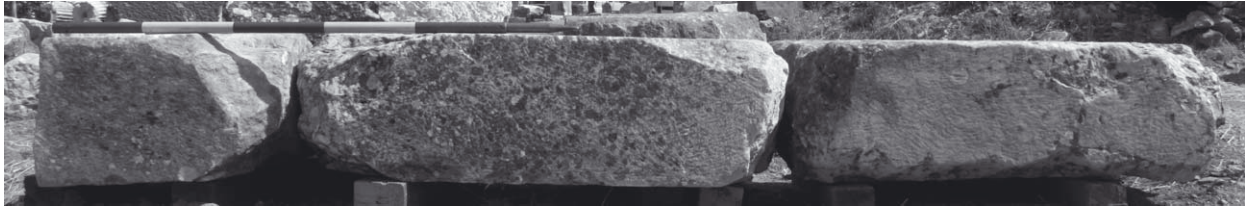

1-2: Architekturprobe B01/532 – B01/523 – B00/87, niedrige Nordwandblöcke der Schicht 24; 1: V; 2: O/R;
 3: B01/523 niedriger Nordwandblock der Schicht 24, U;
 4-10: B00/87 niedriger Nordwandblock der Schicht 24; 4: O; 5: L; 6: V; 7: U; 8: O/H; 9: R; 10: M = 1 : 20.



1

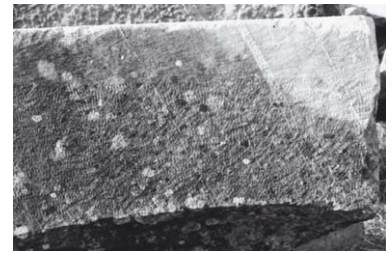

2

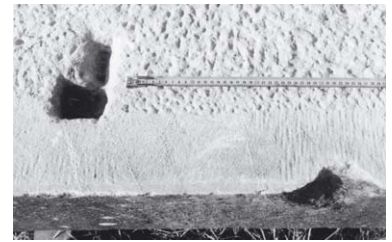

3

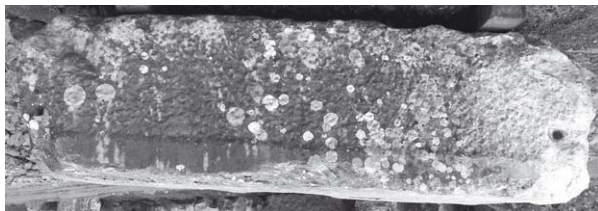

4



6



5



7



9

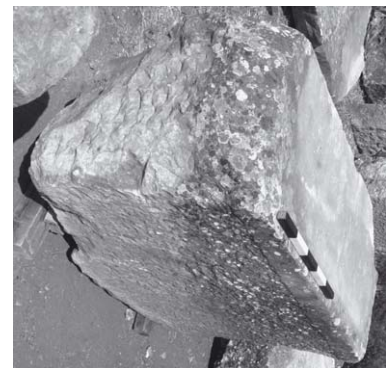

8

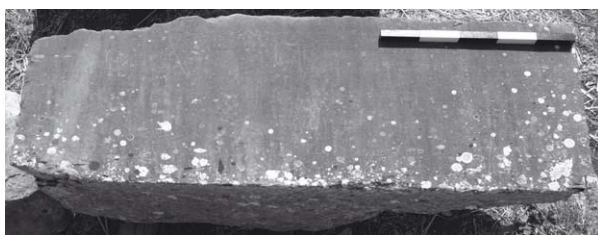

10



11

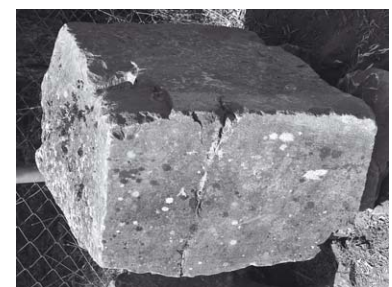

12

1–3: B01/579 äußerer Wandblock einer Hofmauer, 1: O/L/V; 2: Ausschnitt V mit feinerem Kantenschlag entlang der Oberkante; 3: Ausschnitt O mit Saumschlag entlang der Vorderkante;

4–6: B00/72 äußerer Wandblock einer Hofmauer, mit leichter Kantenbosse entlang der Oberkante der V; 4: O; 5: V; 6: R;

7–8: B02/850 äußerer Wandblock einer Hofmauer; 7: O; 8: L/V/U;

9–11: B01/574 äußerer Wandblock einer Hofmauer aus kräftig blaugrauem Marmor; 9: O; 10: V; 11: U;

12: B01/546 äußerer Wandblock einer Hofmauer aus kräftig blaugrauem Marmor, V/L/O.

TAFEL 98



1



2

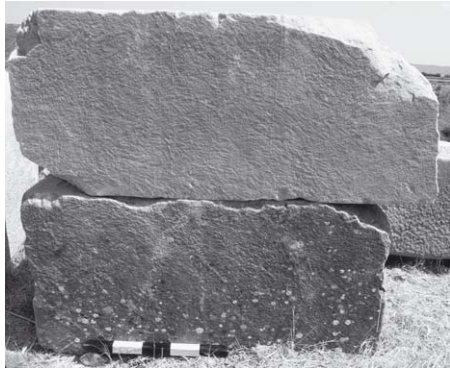

3



4

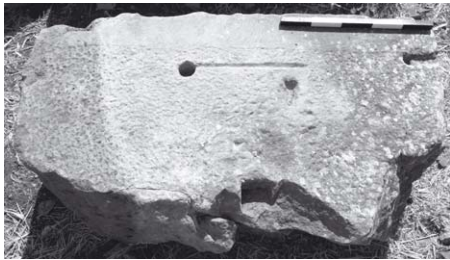

5



7



10



8



6



9



12



11

1-4: Architekturprobe B02/653 – B01/575 – B02/852, äußere Wandblöcke der Südwestecke der Hofmauern; 1: R/H; 2: O; 3: V (Süd) B02/653 – B01/575; 4: U B01/575 – B02/852; 5-6: B02/656 äußerer Eckanschlussblock der Südwestecke der Hofmauern; 5: O; 6: O/L/V; 7-9: B02/852 äußerer Eckanschlussblock der Südwestecke der Hofmauern, Westseite, 7: O; 8: V; 9: L/H; 10: B02/653 äußerer Eckblock der Südwestecke der Hofmauern, O/V (West)/V (Süd); 11-12: B01/575 äußerer Eckblock der Südwestecke der Hofmauern; 11: Detail O mit Gusskanal zur Sichtfläche hin; 12: O.

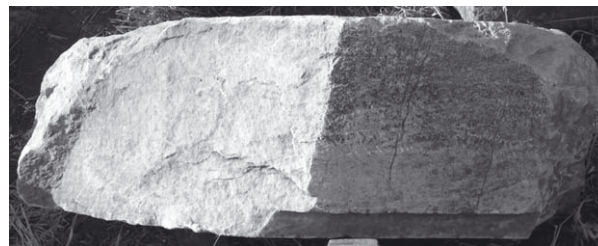
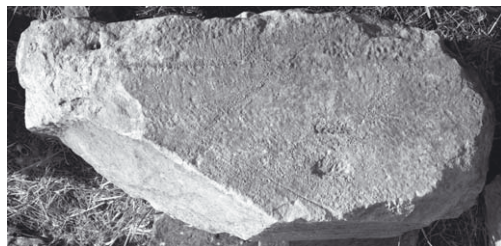
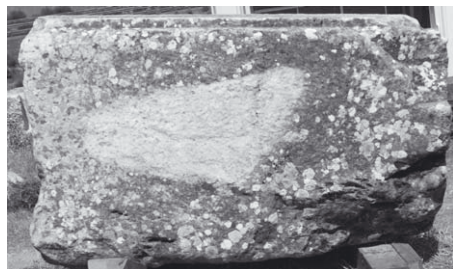
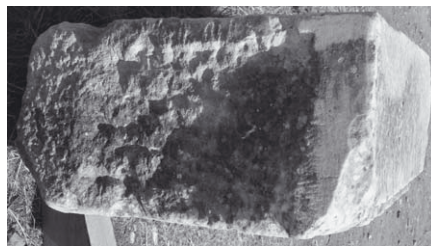
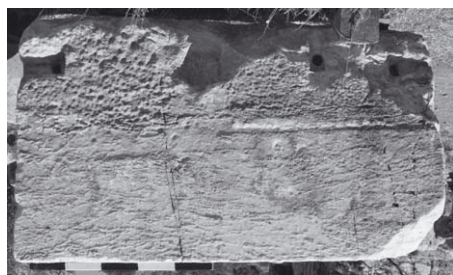
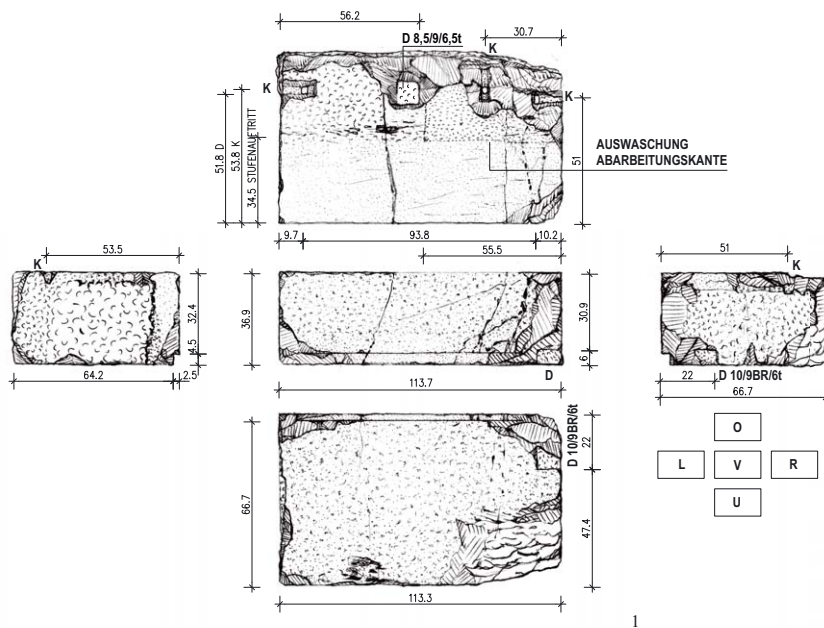

1-6: B01/198 Stufe des Obergeschosses mit Unterschneidung; 1: M = 1 : 20; 2: O; 3: U; 4: L; 5: R; 6: O/R;
7-8: B01/166 Stufe des Obergeschosses mit Unterschneidung; 7: O; 8: V.

TAFEL 100



1

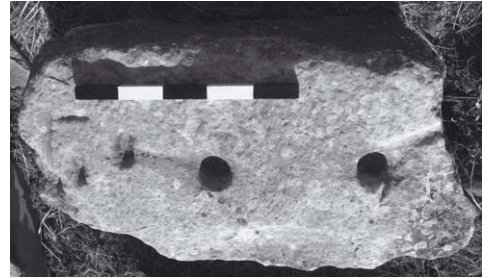

4



2



5



6



3



7



8



11

1–3: Mauerarchitrave der westlichen, südlichen und östlichen Hofmauer, außenseitig, O mit paarweise angeordneten Dübellöchern für die Kassettenquerträger, seitlich davon für die Längsblöcke; 1: B03/1527+1535; 2: B00/12; 3: B01/308+B03/1533; 4–7: B00/25 Mauerarchitrav der östlichen (?) Hofmauer; 4: O mit paarweise angeordneten runden Dübellöchern für den Kassettenquerträger, links davon eines für den Längsblock; 5: L; 6: V; 7: U; 8–10: B02/1032 Mauerarchitrav einer Hofmauer; 8: L; 9: O mit paarweise angeordneten runden Dübellöchern für den Kassettenquerträger, links davon eines für den Längsblock; 10: V; 11–13: B02/872+873+885 Mauerarchitrav einer Hofmauer; 11: L/V/U; 12: O mit paarweise angeordneten runden Dübellöchern für den Kassettenquerträger, rechts davon ein Kantendübel für den Längsblock; 13: U mit Versatzmarke.



9



12



10



13

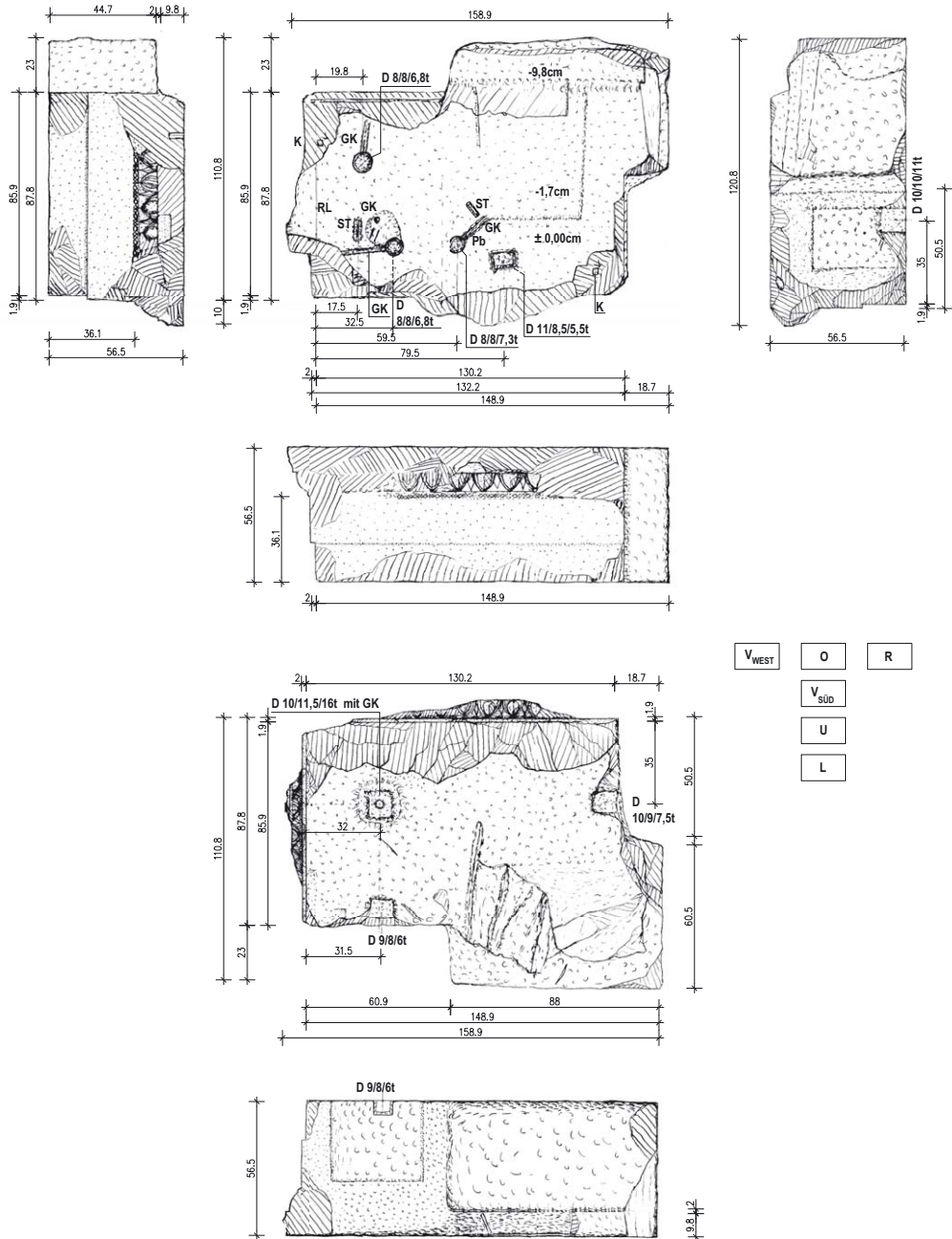

B01/576 Mauerarchitravblock der Südwestecke der Hofmauer, Außenseite, M = 1 : 20.

TAFEL 102

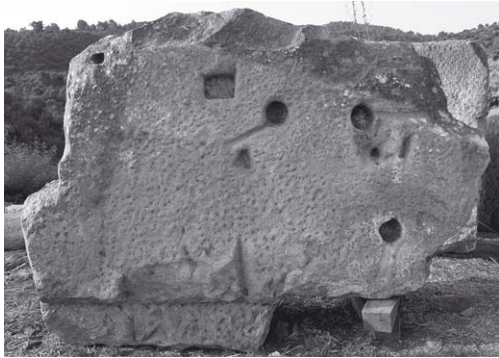

1



2



3



4

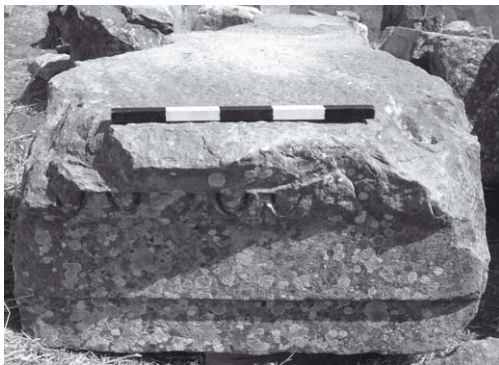

6



5



7



8



9

1–5: B01/576 Mauerarchitravblock der Südwestecke der Hofmauer, Außenseite; 1: O; 2: V (West); 3: U; 4: V (Süd); 5: L.
6–9: B01/567 Mauerarchitrav, Binderblock der westlichen Hofmauer; 6: V; 7: R; 8: O/V/R; 9: O/L.



1



3

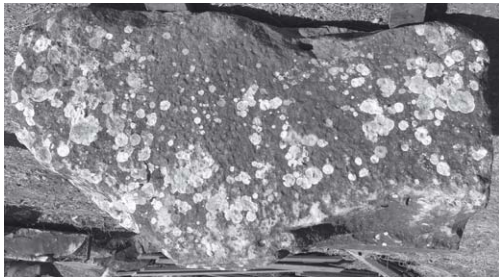

7



8

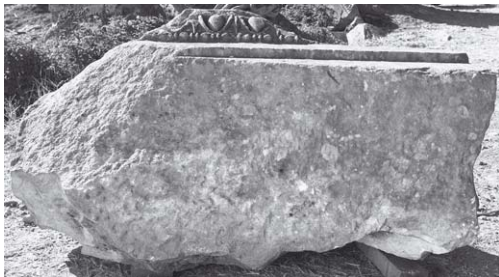

10



2

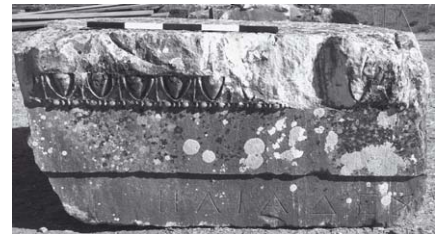

4



5



9

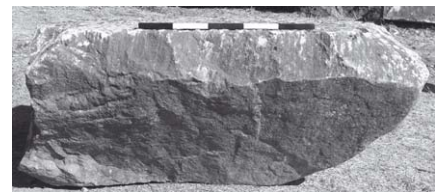

6

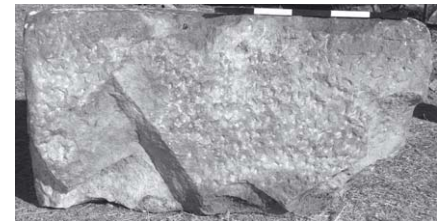

11

1-6: B00/07 Mauerarchitrav, Binderblock der östlichen Hofmauer mit Inschrift ΕΛΙΑΔΕΣ;
 1: O/V/R; 2: O; 3: L (BR); 4: V; 5: U; 6: H (BR);
 7-11: B00/28 Mauerarchitrav, Läuferblock der östlichen Hofmauer mit Inschrift ...ΕΥΣ; 7: O;
 8: V; 9: R; 10: U; 11: H.

TAFEL 104

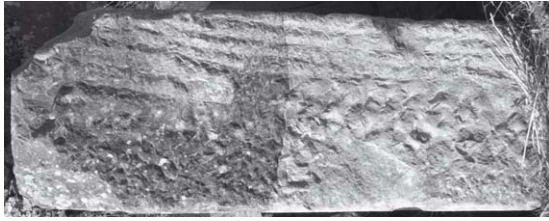

1

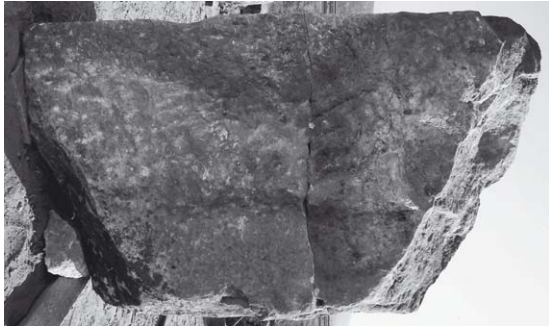

2



3



4



8



5

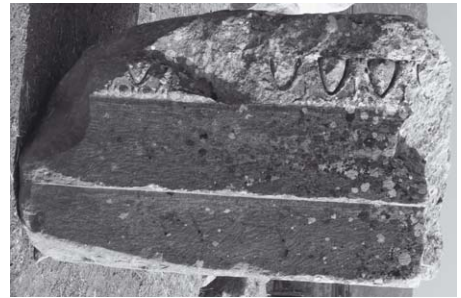

6

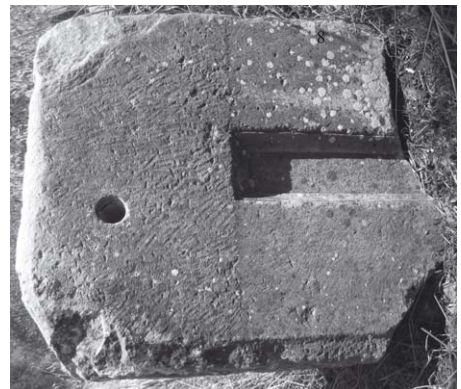

7



9

1-4: B01/485 Blendarchitrav vor der nördlichen Hofmauer; 1: H; 2: O; 3: V; 4: U;
5-9: B01/529 Blendarchitrav vor der nördlichen Hofmauer; 5: O; 6: V; 7: U; 8: H; 9: L.

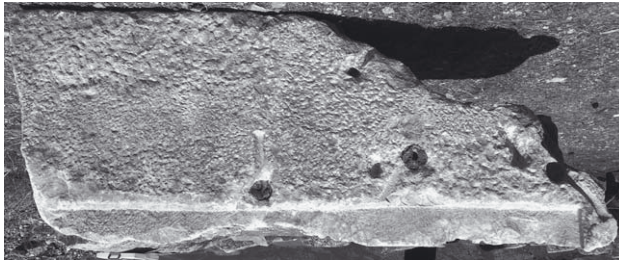
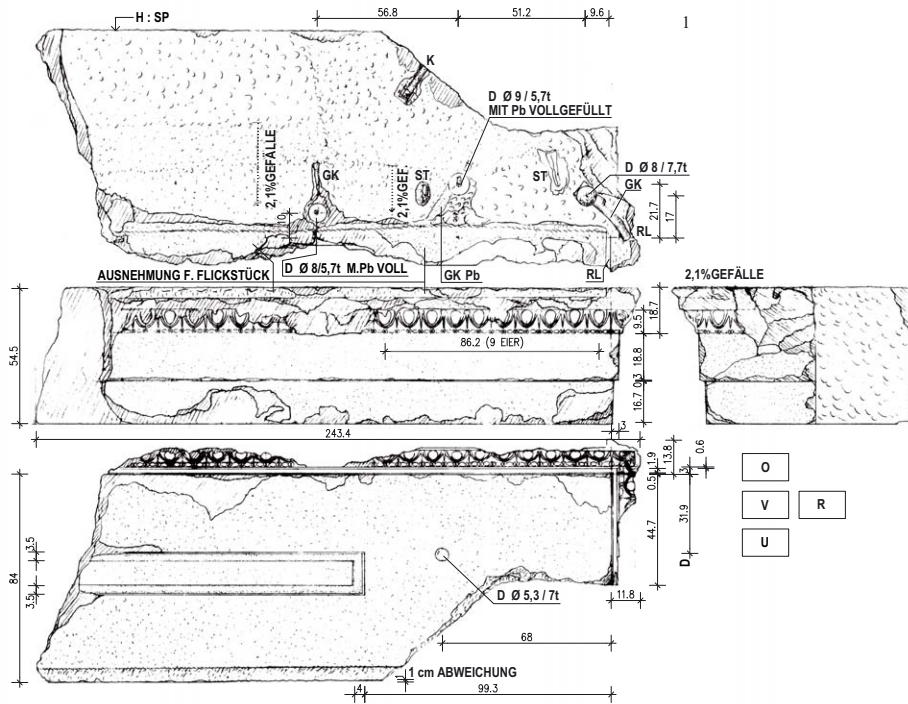

2



4

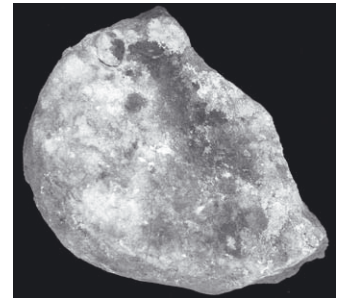

5



3

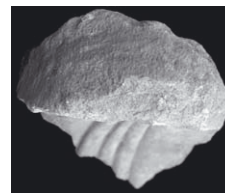

6

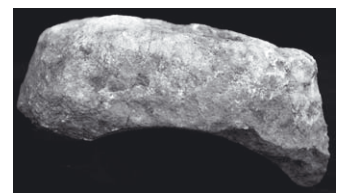

7

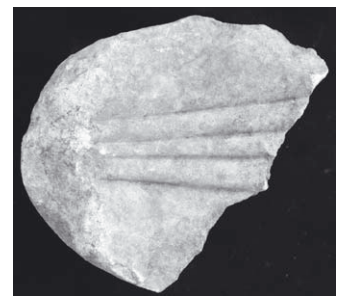

8

1-4: B01/494 Blendarchitrav vor der nördlichen Hofmauer, Nordwestecke;
 1: M=1 : 20; 2: O; 3: U; 4: V (West);
 5-8: B03/1596 Blattkelchkapitell, Fragment einer Blattspitze; 5: O;
 6: V/L/U; 7: R; 8: U.

TAFEL 106



1

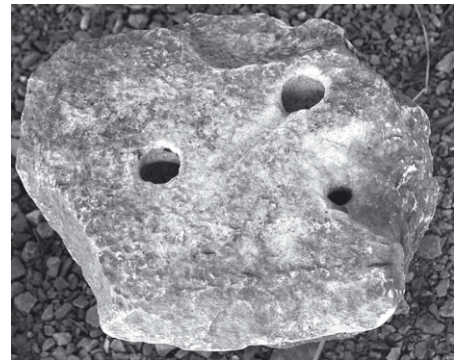

2



3



4



5

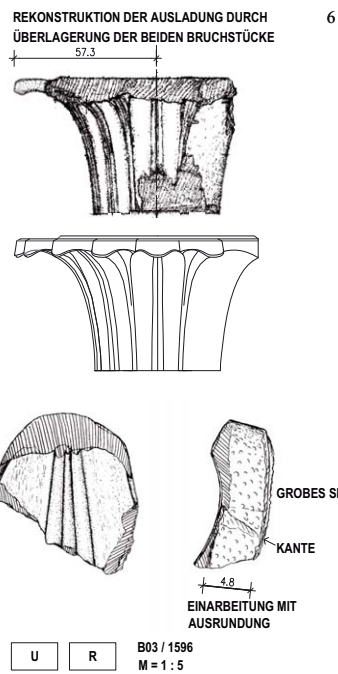
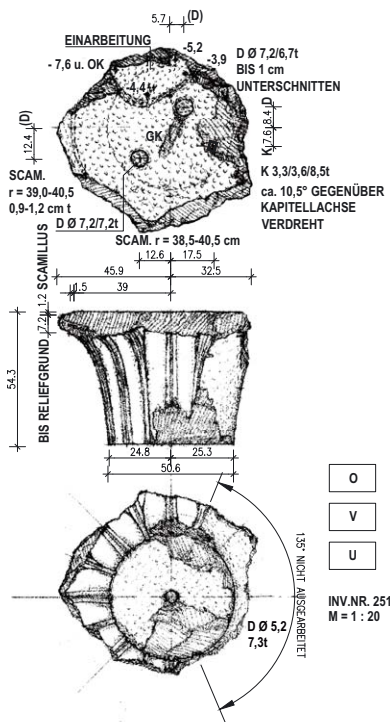

1-6: Blattkelchkapitell Inv.Nr. 251 Freiluftdepot Ephesos;
 1: H; 2: O; 3: L; 4: V; 5: R; 6: Inv.Nr. 251 M = 1 : 20 und B03/1596, Fragment einer Blattspitze, M = 1 : 5.

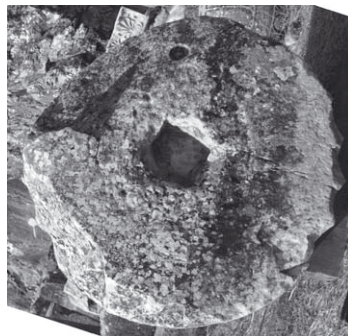
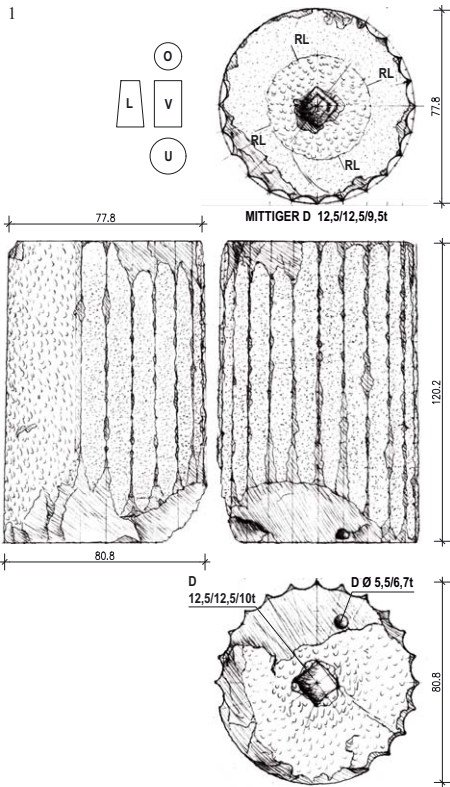

2

3

4

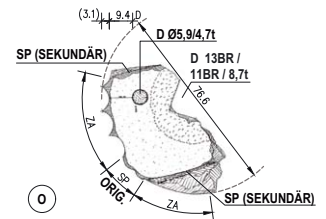

5

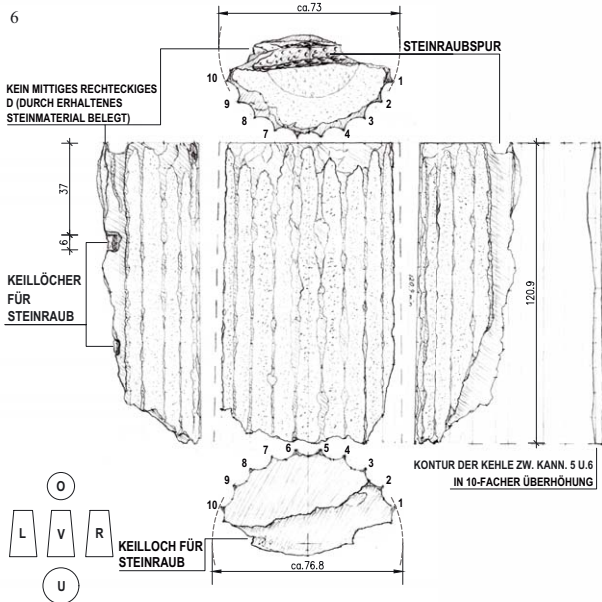

1-4: B01/453 untere dorische Trommel mit unvollständiger Kannelierung; 1: M = 1 : 20; 2: O/H/L; 3: O/V/R; 4: U;
 5: B05/1691 dorische Trommel mit unvollständiger Kannelierung; U;
 6: B01/503 mittlere dorische Trommel, M = 1 : 20;
 7: B01/502 mittlere dorische Trommel mit unvollständiger Kannelierung, O/R.

7

TAFEL 108

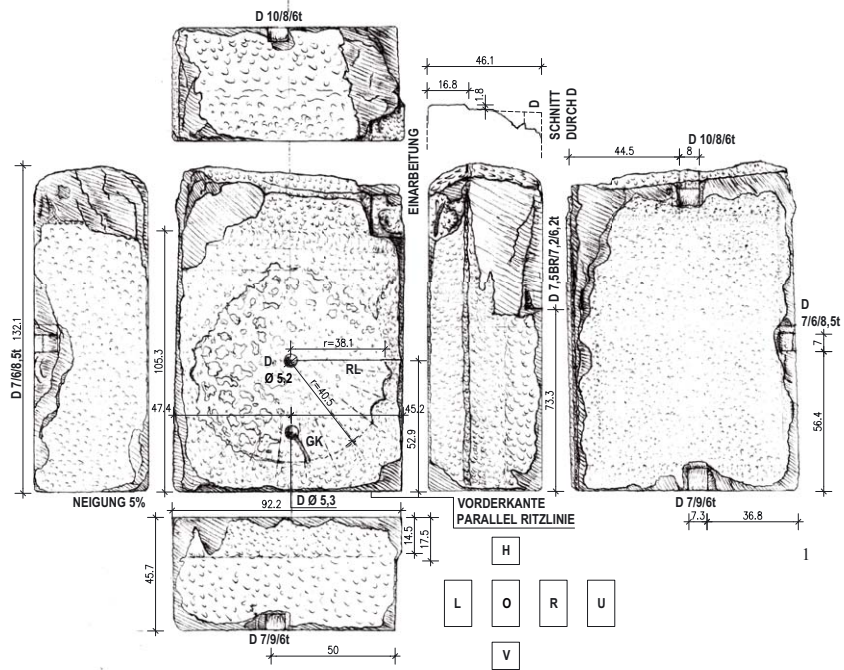

2

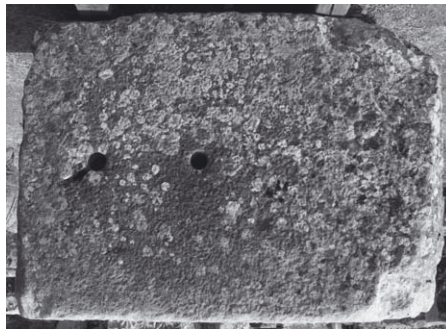

3



4



5



6



7

1-7: B01/514 Stylobat einer dorischen Säule;
1: M = 1 : 20; 2: L; 3: O; 4: V; 5: R; 6: H; 7: U.

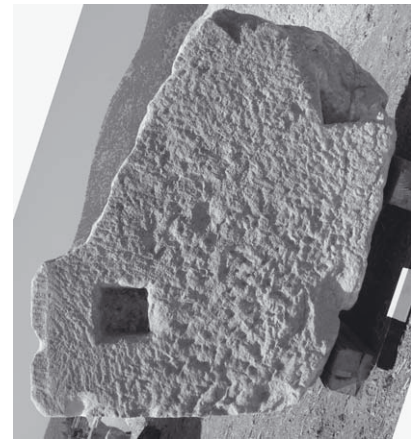
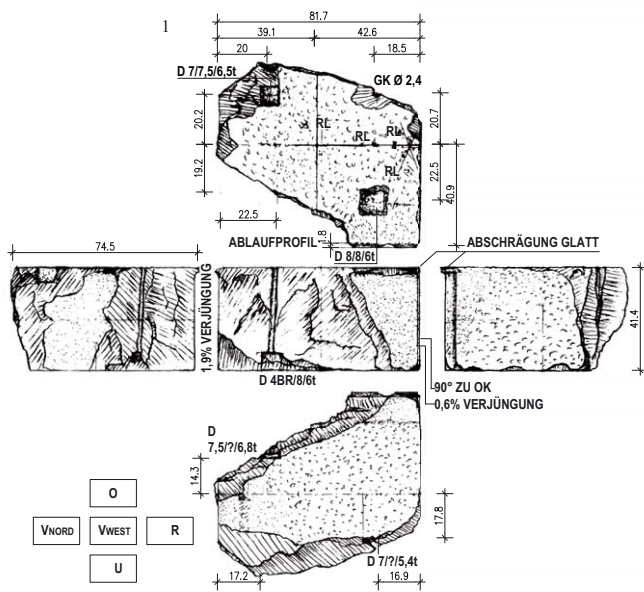

2



3



4



5



6



7



8

1-8: B02/984 Ablaufblock des westlichen Antennefeilers der Nordfassade im OG;
1: M = 1 : 20; 2: O; 3: V (Nord); 4: V (West); 5: R; 6: L (BR); 8: O/V(West)/R.

TAFEL 110

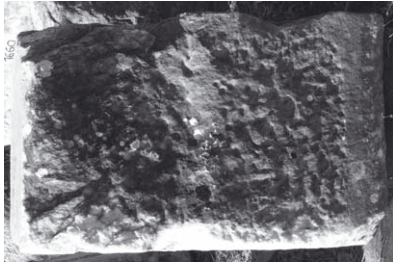

1



2

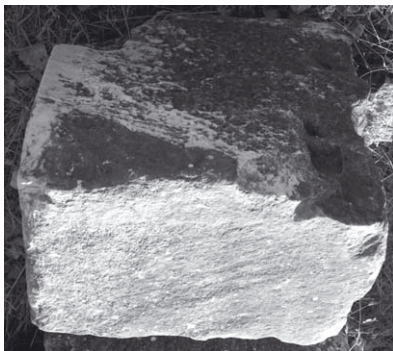

3



7



5

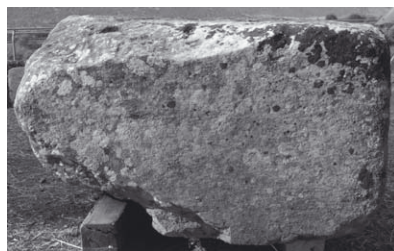

8



6

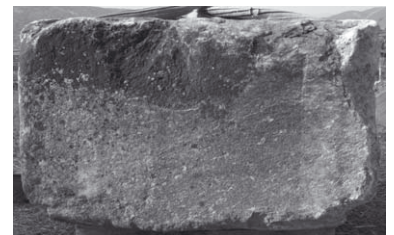

9



10

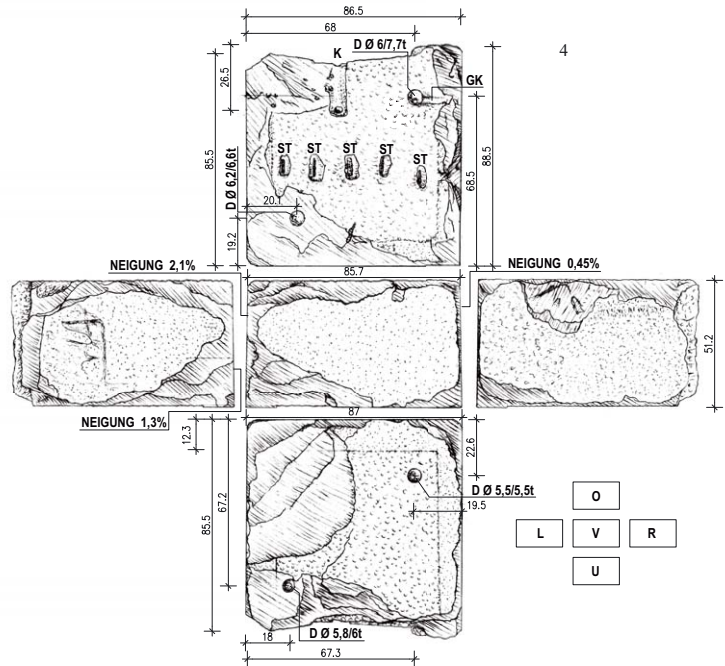

1-3: B00/61 Block des östlichen Antennefeilers der Nordfassade im OG; 1: H; 2: U; 3: O/R;
 4-10: B01/476 Block mit drei Sichtflächen der Nordfassade im OG;
 4: M = 1 : 20; 5: O; 6: H; 7: V (L); 8: V (Nord); 9: V (R); 10: U.

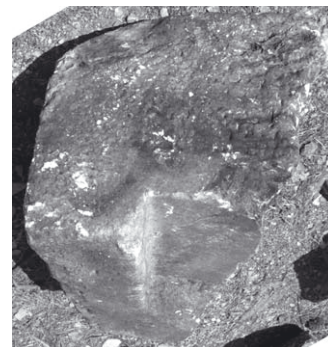
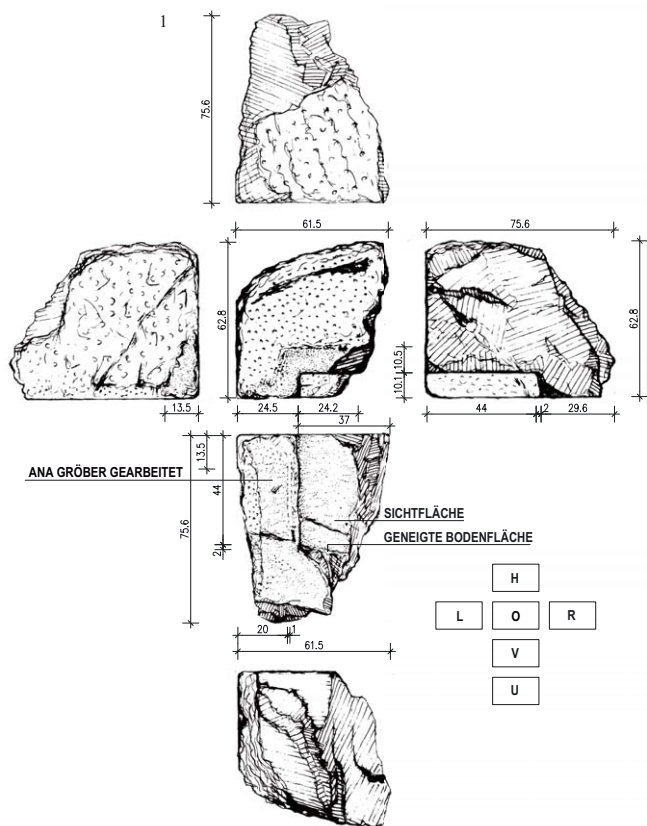

2



3



4

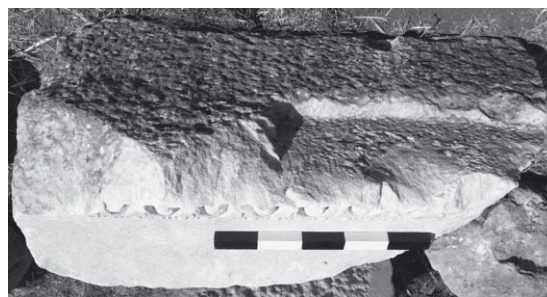

5

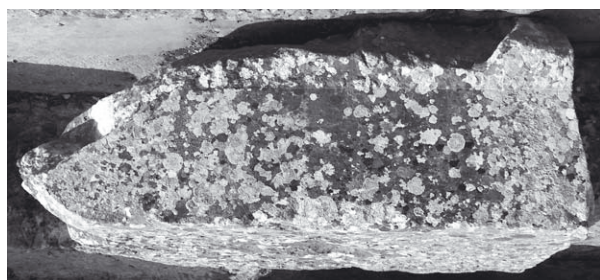

7



6

1-3: B02/1329 Block mit Innenecke (Pfeileransatz?); 1: M = 1 : 20; 2: O/V; 3: V;
 4-6: B01/516 Block mit Wandabschlussprofil der Nordfassade im OG; 4: L/O; 5: O/V mit Vierungsausnehmung; 6: V;
 7: D1320 Block mit Wandabschlussprofil der Nordfassade im OG, V.

TAFEL 112



1

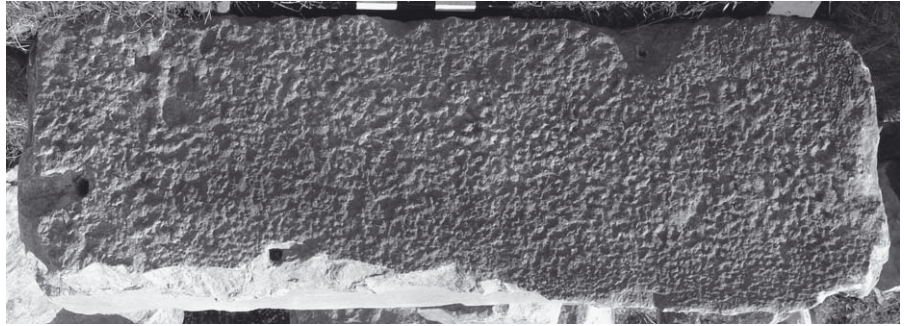

2

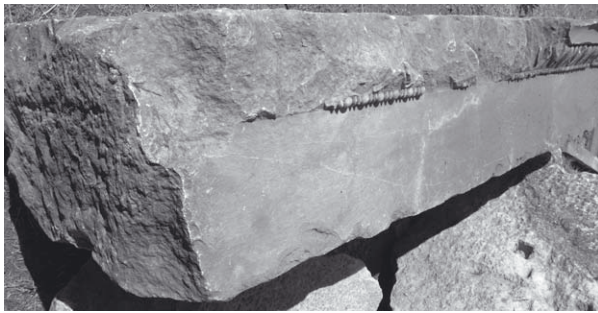

3



4

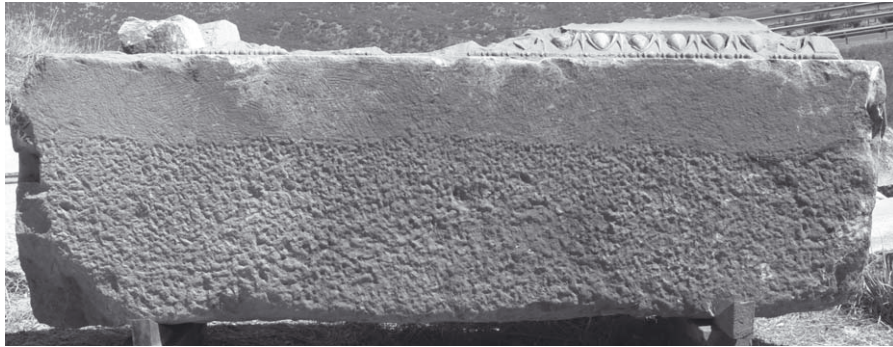

5

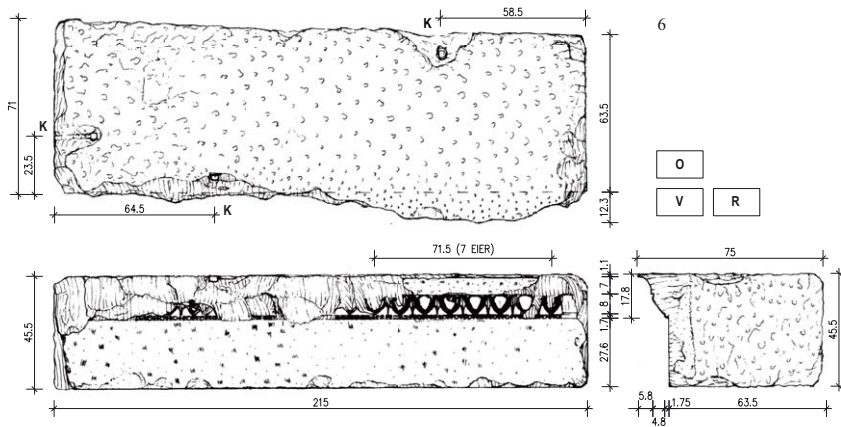

1-6: B03/1476 Block mit Wandabschlussprofil der Nordfassade im OG;
 1: Detail O/V mit Klammerloch zur Sichtseite hin; 2: O; 3: L/V; 4: V/R; 5: U; 6: M = 1 : 20.



1



2



3



4



5

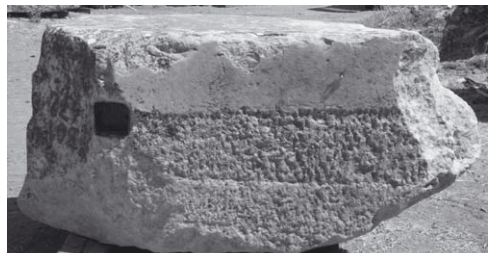

6

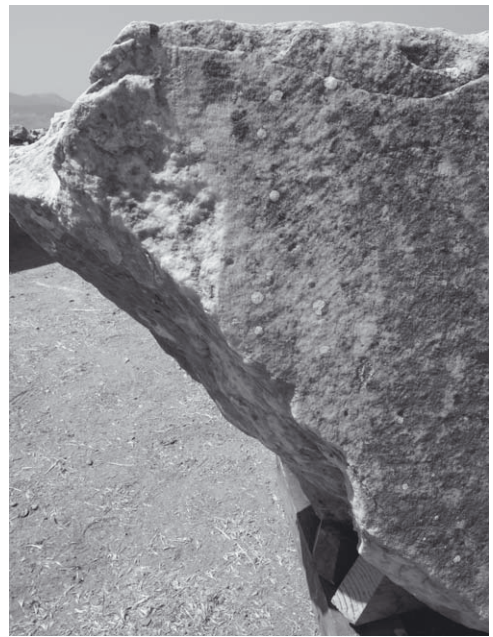
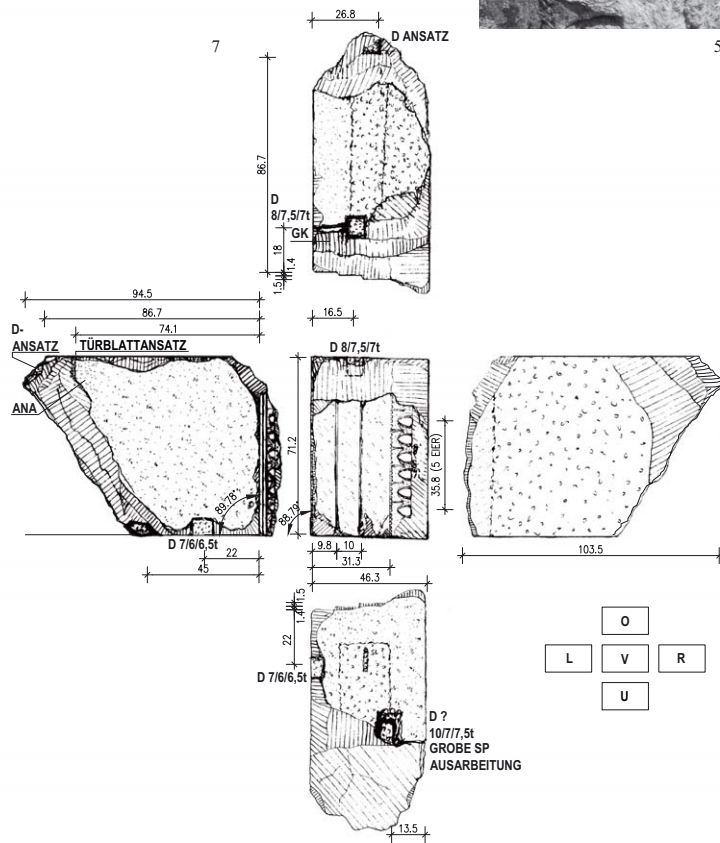

8

1-8: Gewändeblock der Tür der Nordfassade im OG;
 1: L (Leibung); 2: V; 3: R; 4: U; 5: Detail V Profilierung;
 6: O; 7: M = 1 : 20; 8: Detail L mit Leibungsende.

TAFEL 114



1



2



3



4

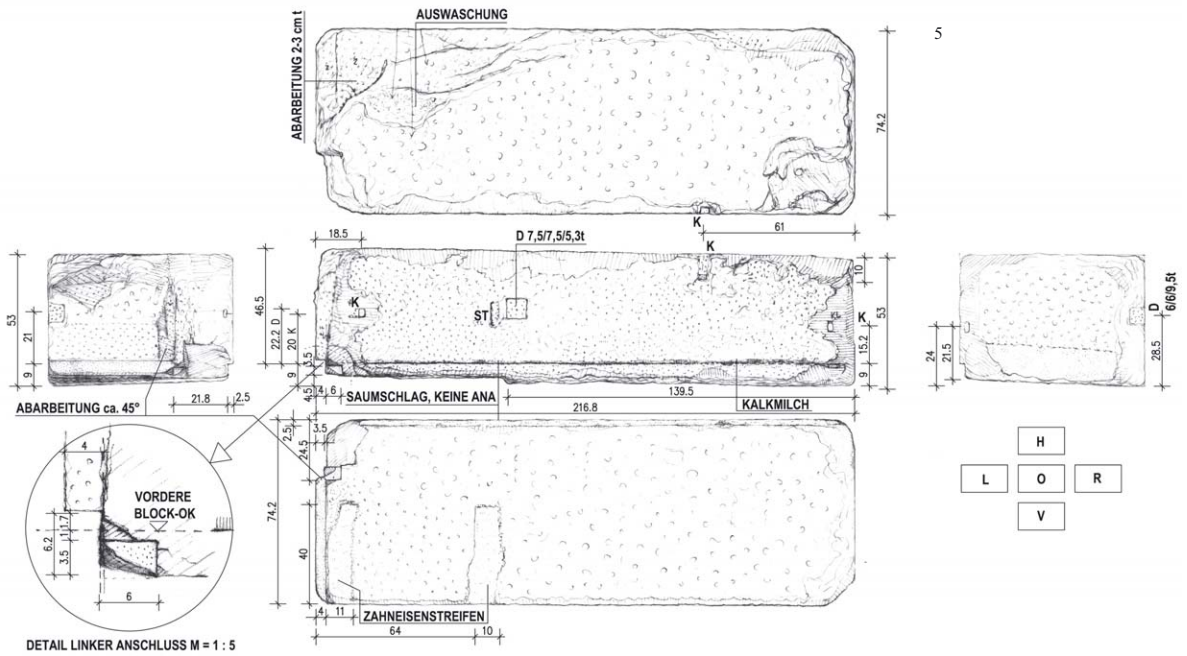

1-5: D1368 Gewändeanschlussblock mit Bosse der Nordfassade im OG;
 1: Detail V linke Stoßkante mit Ausnehmung für Sturzblock; 2: L; 3: R; 4: V; 5: M = 1 : 20.

TAFEL 116



1



2



3



4



5

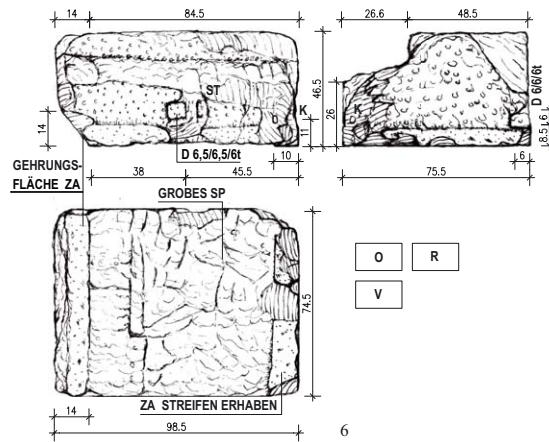

6



7



8

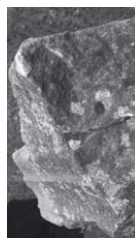

9

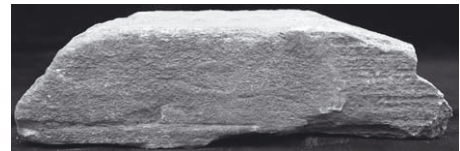

10



11

1-6: B02/1100 Gehrungsblok der Nordfassade im OG; 1: L;
 2: V; 3: R; 4: O; 5: O/H; 6: M = 1 : 20;
 7: B01/551 Wandblock der Nordfassade im OG, V;
 8-9: B01/497 Profilfragment; 8: V; 9: R (BR);
 10-11: Profilfragment; 10: L (BR); 11: O/V.



1



2



5



6

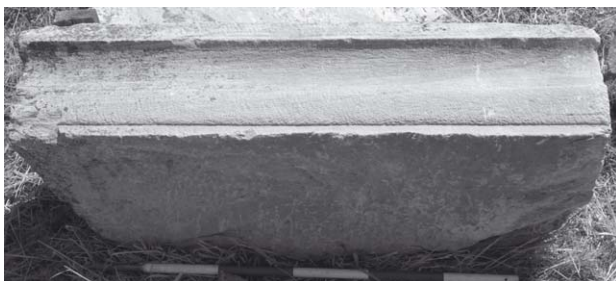

3

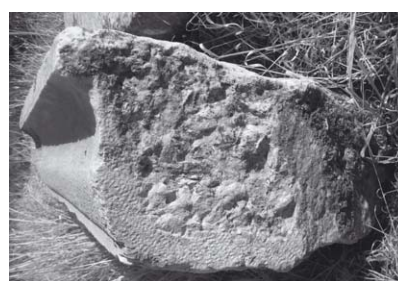

4

1: Felssockel mit Überbauung, Draufsicht, im Vordergrund Reste der nördlichen Hofmauer mit verstärktem Mittelteil;
 2-4: Türbekrönung oder Gesims eines späteren Gebäudes; 2: O; 3: V/U; 4: R;
 5-6: vermutliche Gesimsblöcke eines späteren Gebäudes im Profil (vorkragende Steinblöcke als Stuckgrund).

TAFEL 118

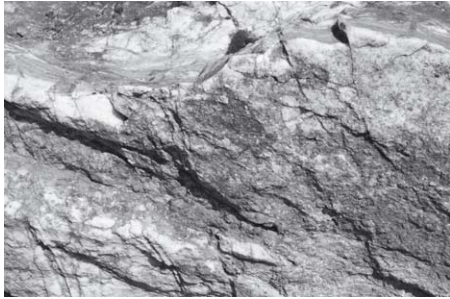

1

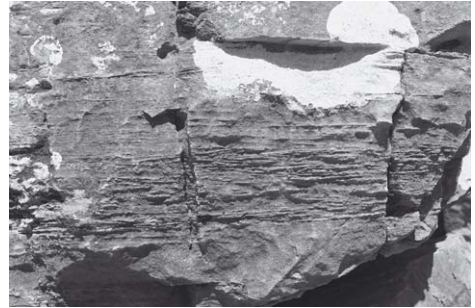

2



3



4



5

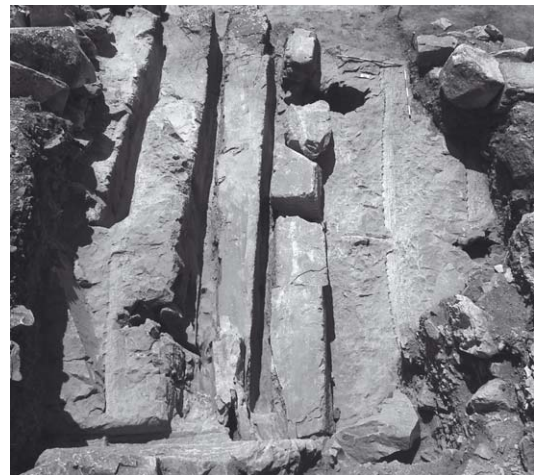

6

- 1: Marmor des Felssockel;
 2: Marmor des Felssockels mit dolomitischen Unreinheiten;
 3: Marmor des Felssockels mit Spalten und Klüften;
 4: weißer und blaugrauer Marmor der Verkleidungsarchitektur;
 5: Mauerwerk der nördlichen Hofmauer, Außenseite Mittelbereich (oberster Block Schicht 25), Blockoberflächen mit Bearbeitungsspuren vom Steinbruch;
 6: Terrasse im Osten, Blockabbau mittels Schrotgräben, Aufsicht;
 7: Terrasse im Osten, Blockabbau mittels Schrotgräben im Gefälle gemäß Steinschichtung, Blick von Norden.

7





1



2



3



4



5



6

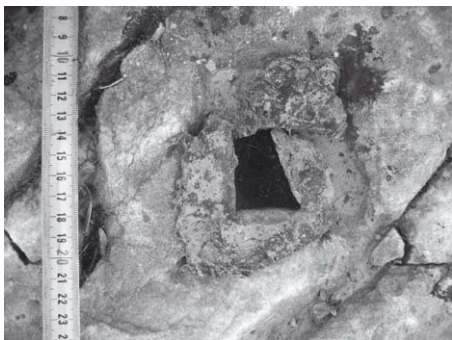

7



8

- 1: Mauerblock mit Rest eines Schrotkanals;
- 2: Keilsprengspuren auf dem Felssockel;
- 3: Mörtelpackung hinter einem Verkleidungsblock der Schicht 6 an der Westseite;
- 4: römische Aristion-Wasserleitung an der Westseite;
- 5: Mörtel des Mausoleums;
- 6: Dichtungsmörtel der römischen Aristion-Wasserleitung;
- 7: Dübelloch mit Bleifüllung und Abdruck des Dübels auf dem Felssockel im nördlichen Bereich der Westhofmauer;
- 8: Dübelloch mit Bleifüllung und Abdruck des schiefliegenden Dübels auf dem Felssockel im Westpteron.

TAFEL 120



1

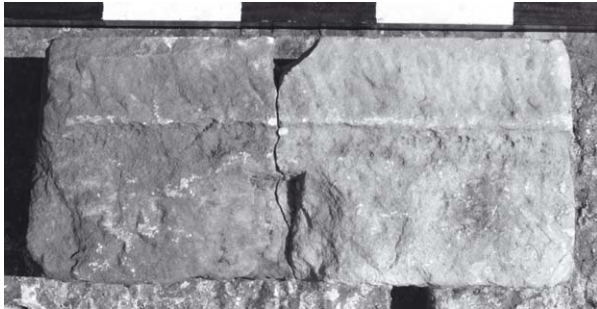

2

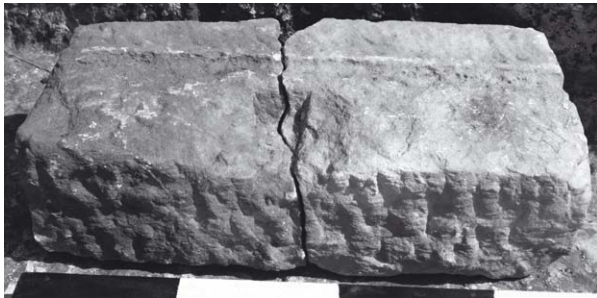

3

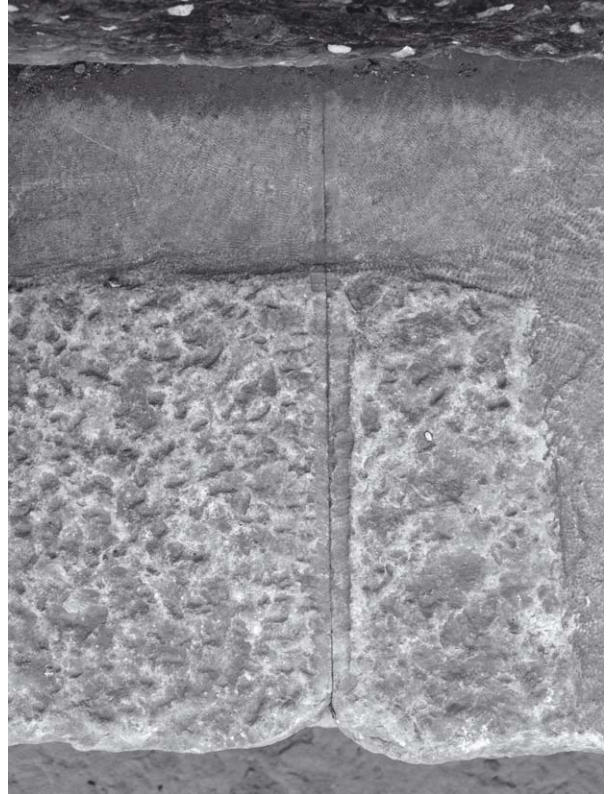

4

1–3: B03/1569 Vierungseinsatz vom Bekrönungsprofil auf der Rückseite eines Peristasisarchitravs, mit Schwalbenschwanzklammer zur Verbindung mit dem Architrav;
1: V/U; 2: O; 3: O/H.
4: Krepis des Sockelgeschosses, Stufenoberseite mit noch anstehender Bosse und Kantenschlag entlang der Stoßfuge.

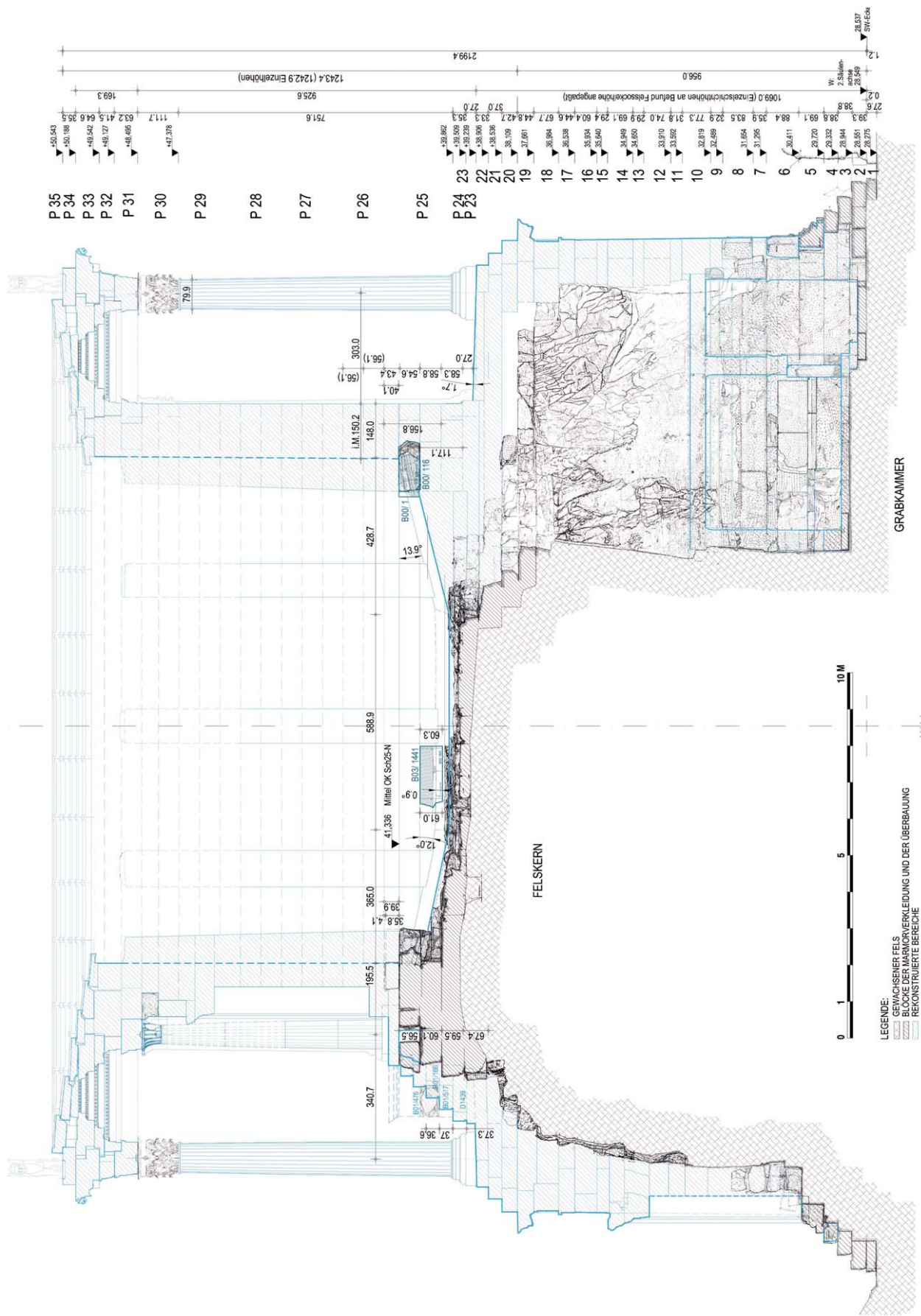

N-S-Schnitt Rekonstruktion mit Bestand M = 1 : 100.

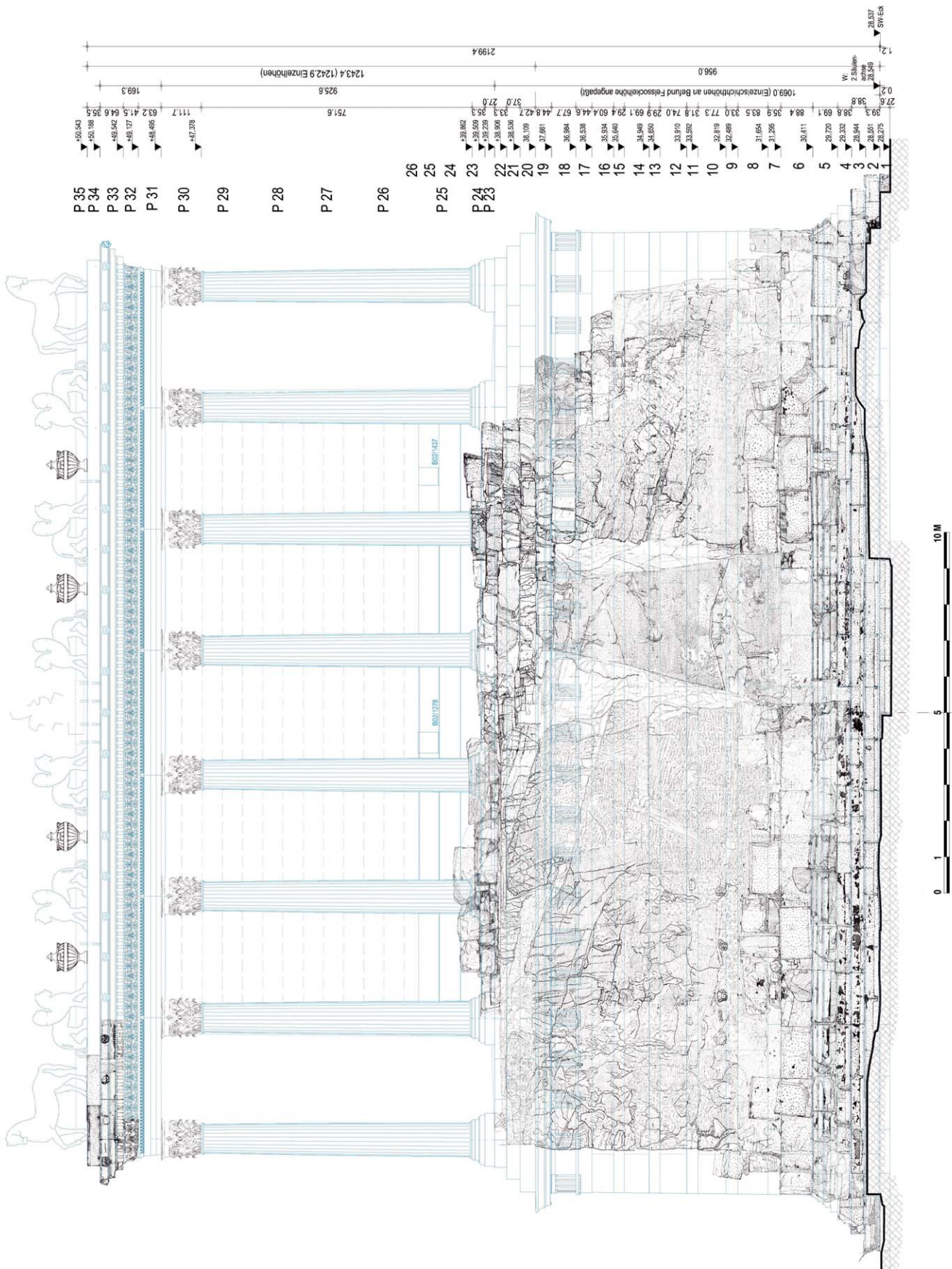

S-Fassade Rekonstruktion mit Bestand M = 1 : 100.

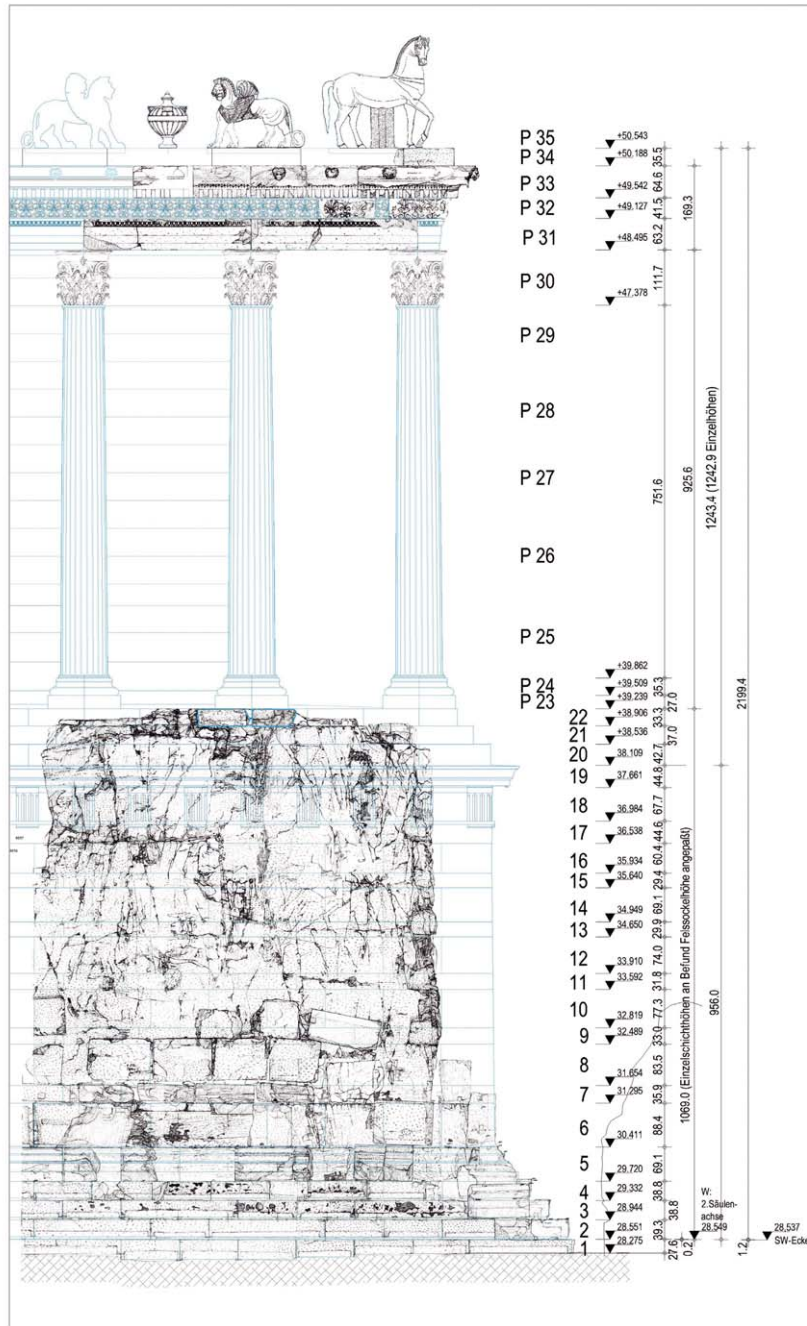

W-Fassade, Südteil Rekonstruktion mit Bestand M = 1 : 100.

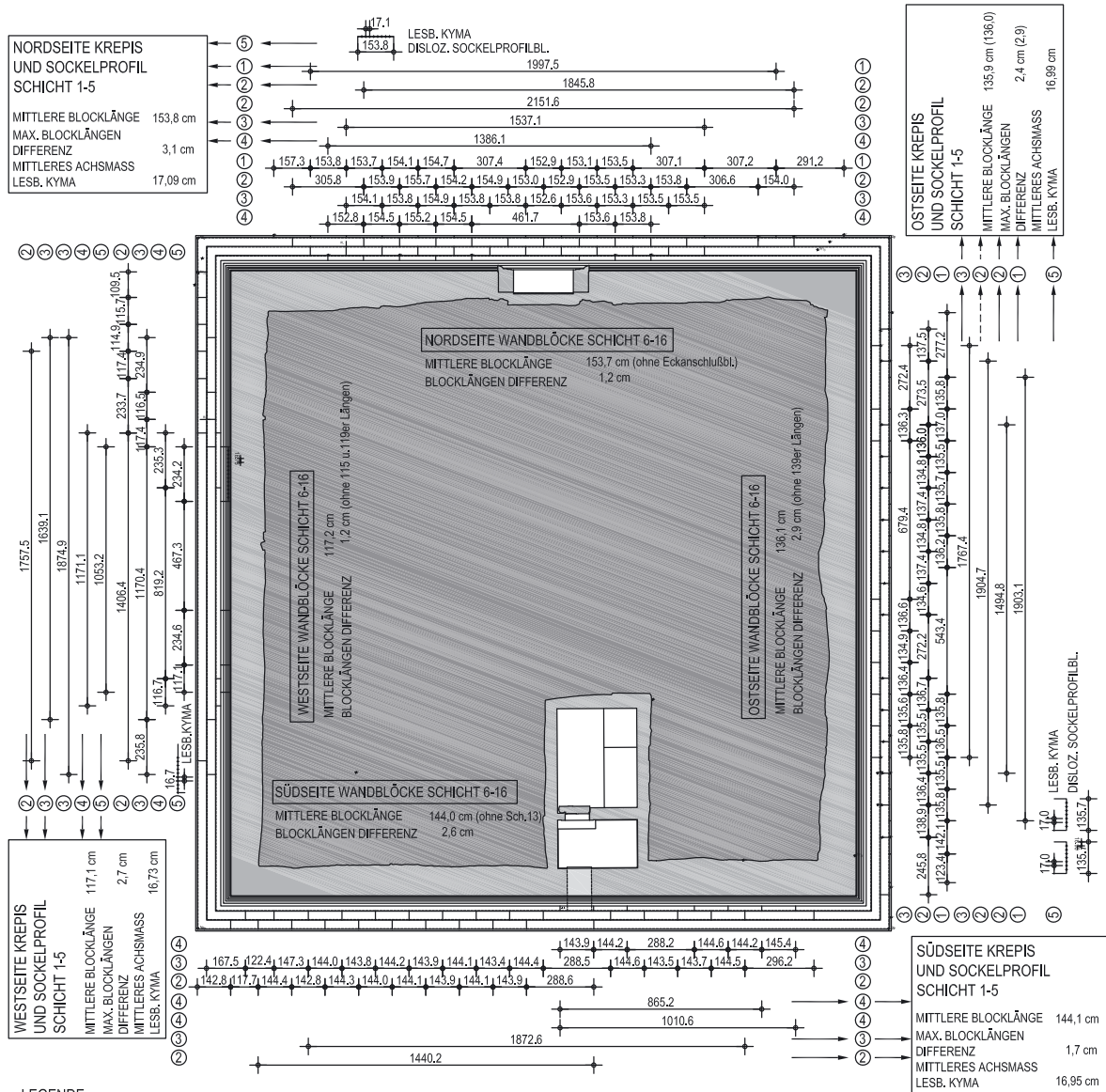

Grundriss Sockelgeschoss mit Blocklängen des Verkleidungsmauerwerks M = 1 : 200.

LEGENDE

- VERKLEIDUNGSBLÖCKE IN SITU
- DRUCK VERKLEIDUNG IN REKONSTR. LAGE
- DRUCK BLÖCKE AN SOZEL
- GEBREMTE STOSSFLÄCHEN
- REKONSTR. STOSSFUGEN
- ÜBERBLEICH
- ANFENDBREIHEL UNTERER TEIL MIT ANGABE DER STOSSELAGE
- ÜBERBLEICH MIT GEDARTETEM GUSSWANAL
- STEINLOCH
- SEITL. STEINLOCH
- UNTERES STEINLOCH
- ALUMINER
- VERSÄTZUNG DES BLOCKES
- REKONSTR. VERSÄTZUNG
- RITZLINE
- SEITE OHNE ÜBERBLEICH
- SEITE ODER ERREICH NICHT ERREICHBAR
- BOSENANBEITUNG AM AUFTRIFF DER L. UN
- WÜRTELSPREIBEN MIT HIMMER AUF STOSSELÖCH

ERHALTENE / ZUGÄNGLICHE BLÖCKE	STÜCK	PROZENT-SATZ
	2/22	9,09%
	2/22	9,09%
	3/22	13,6%
	8/22	36,4%
	11/22	50,0%
	12/22	54,5%

DISLOZIERTE LÄUFERBLÖCKE W-SEITE

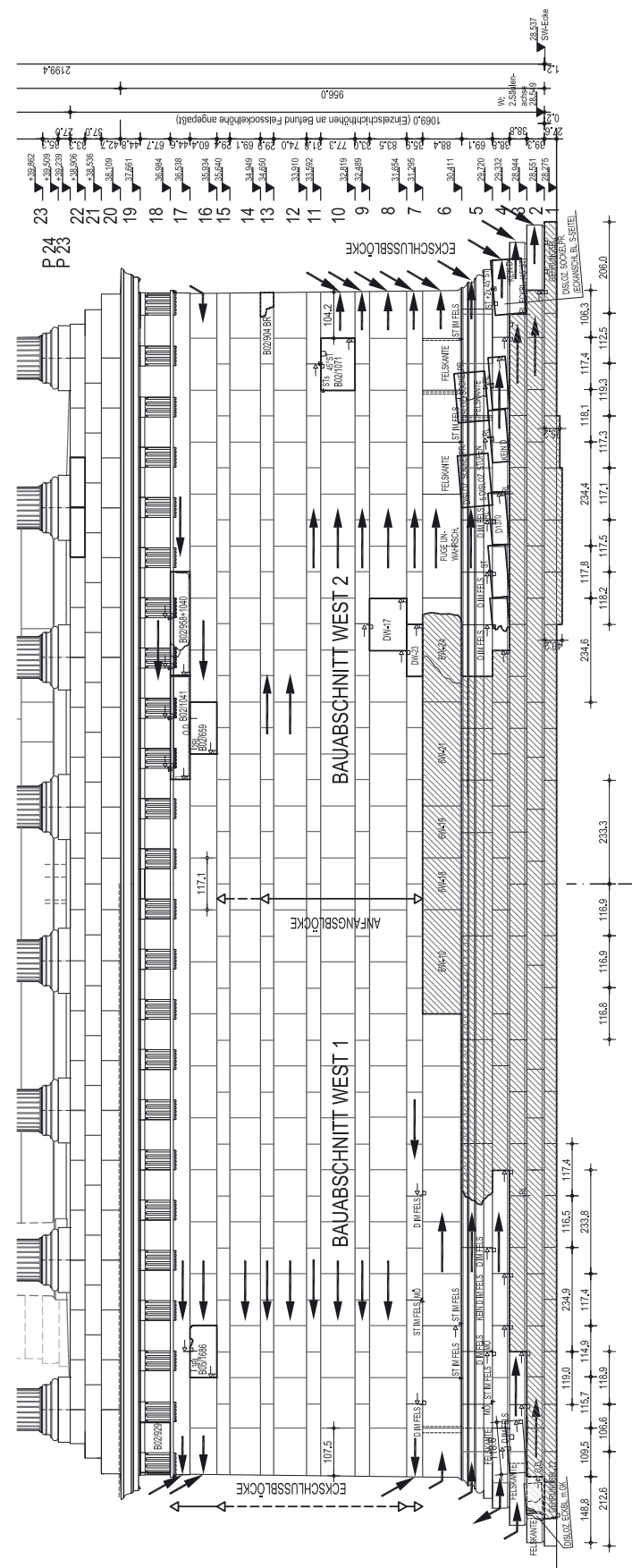

Sockel W-Seite M = 1 : 100 mit dislozierten Läuferblöcken.

TAFEL 133

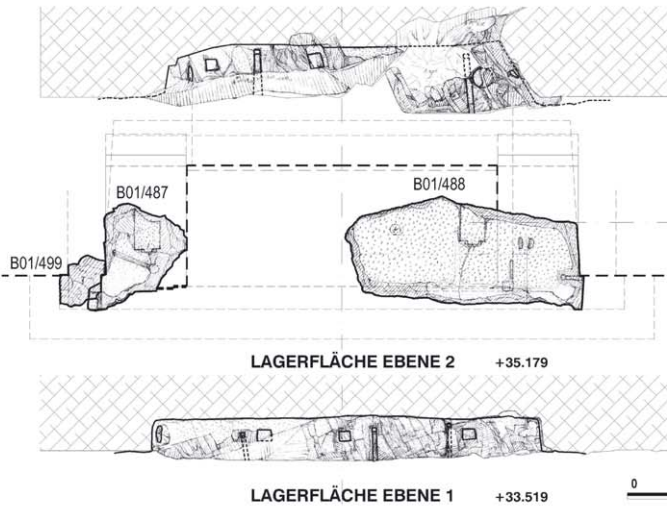
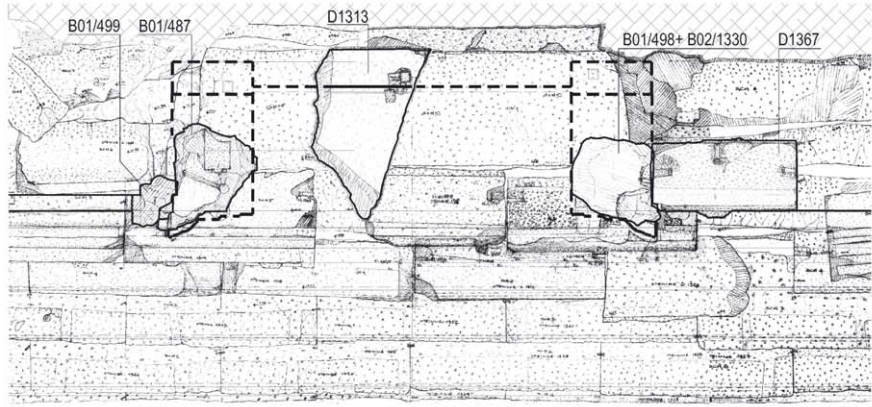
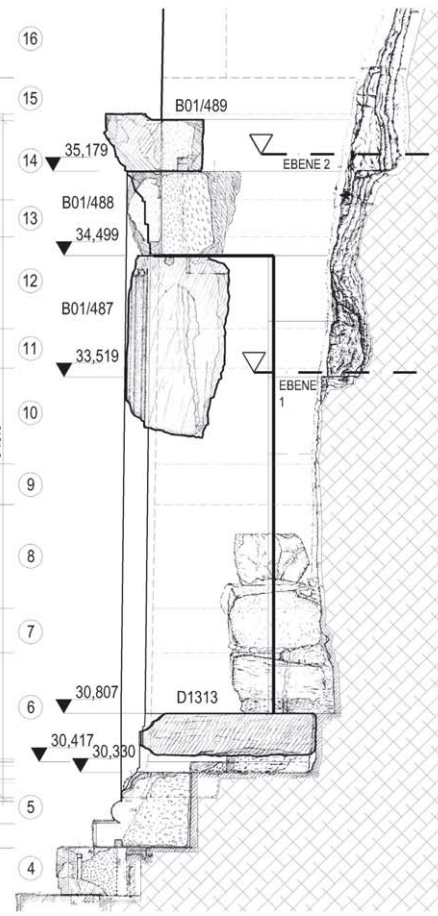
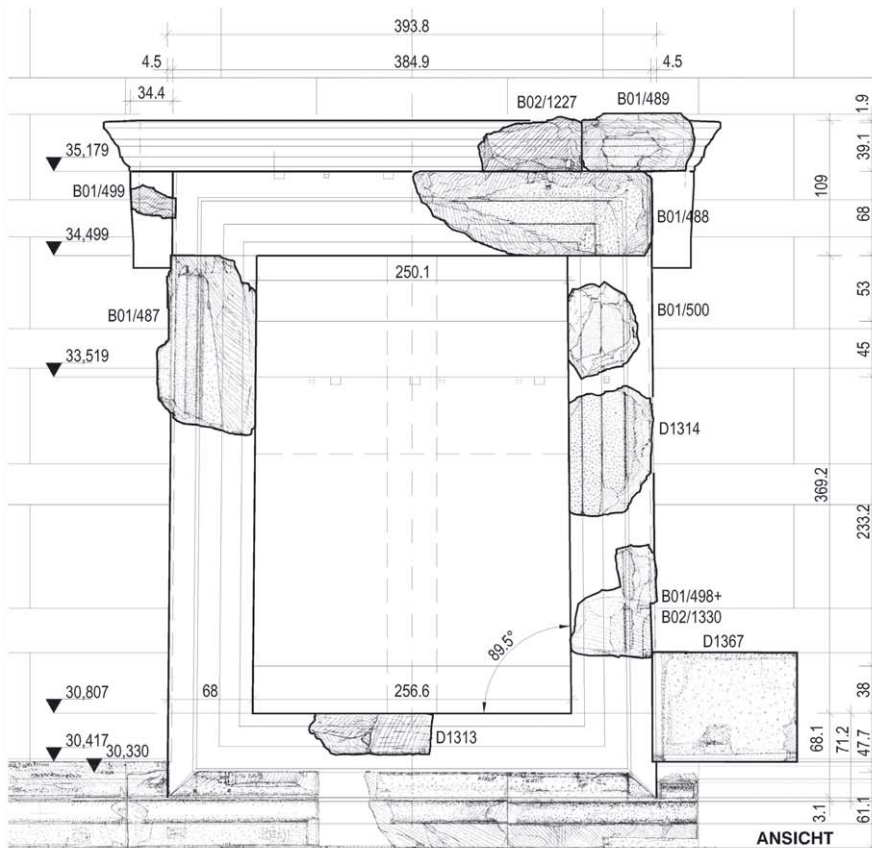

Scheintür Rekonstruktion mit Bestand M = 1 : 40.



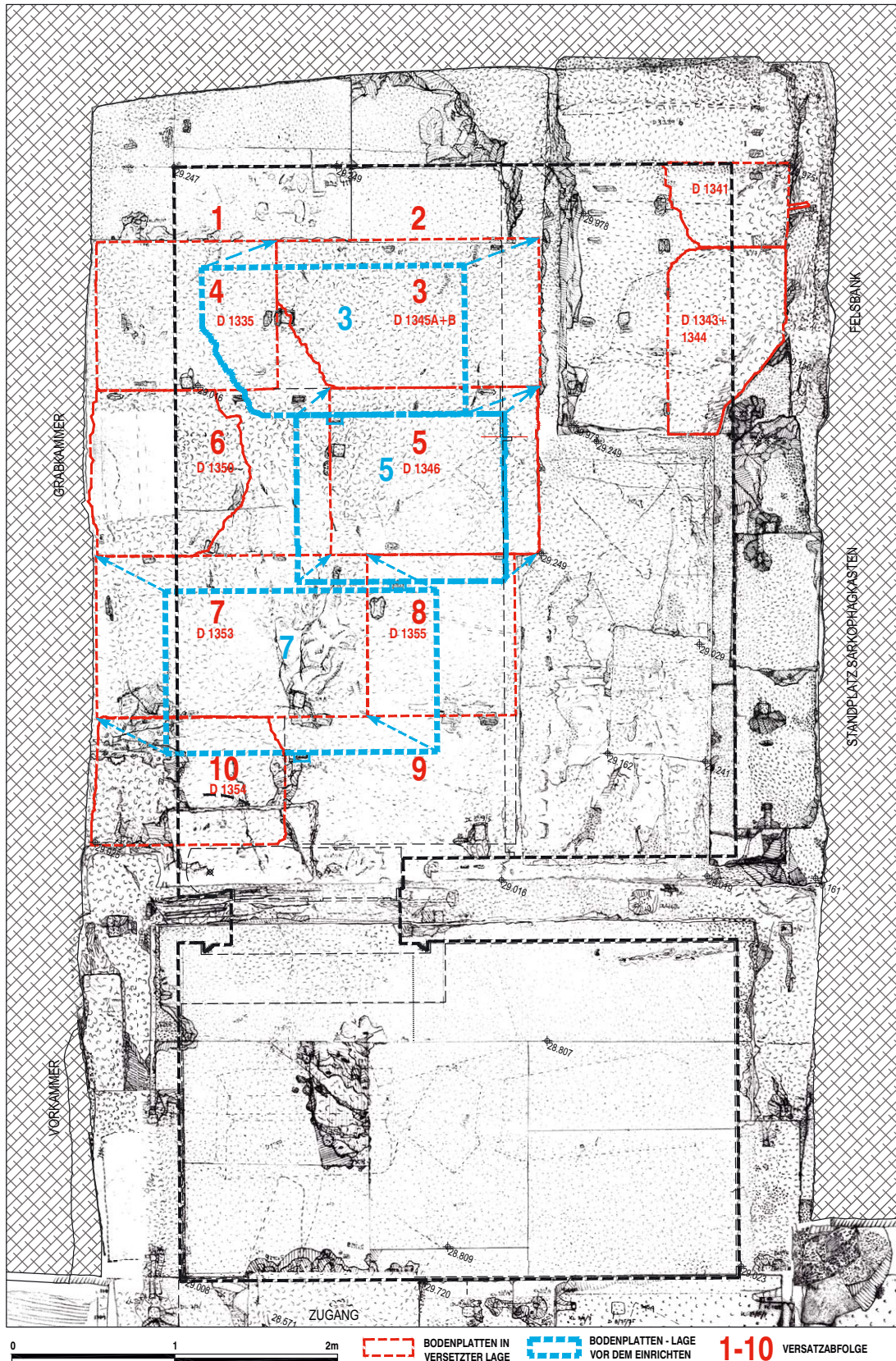

Grabkammergrundriss, Bestand mit Rekonstruktion des Versatzablaufes für die Bodenplatten M = 1 : 25.

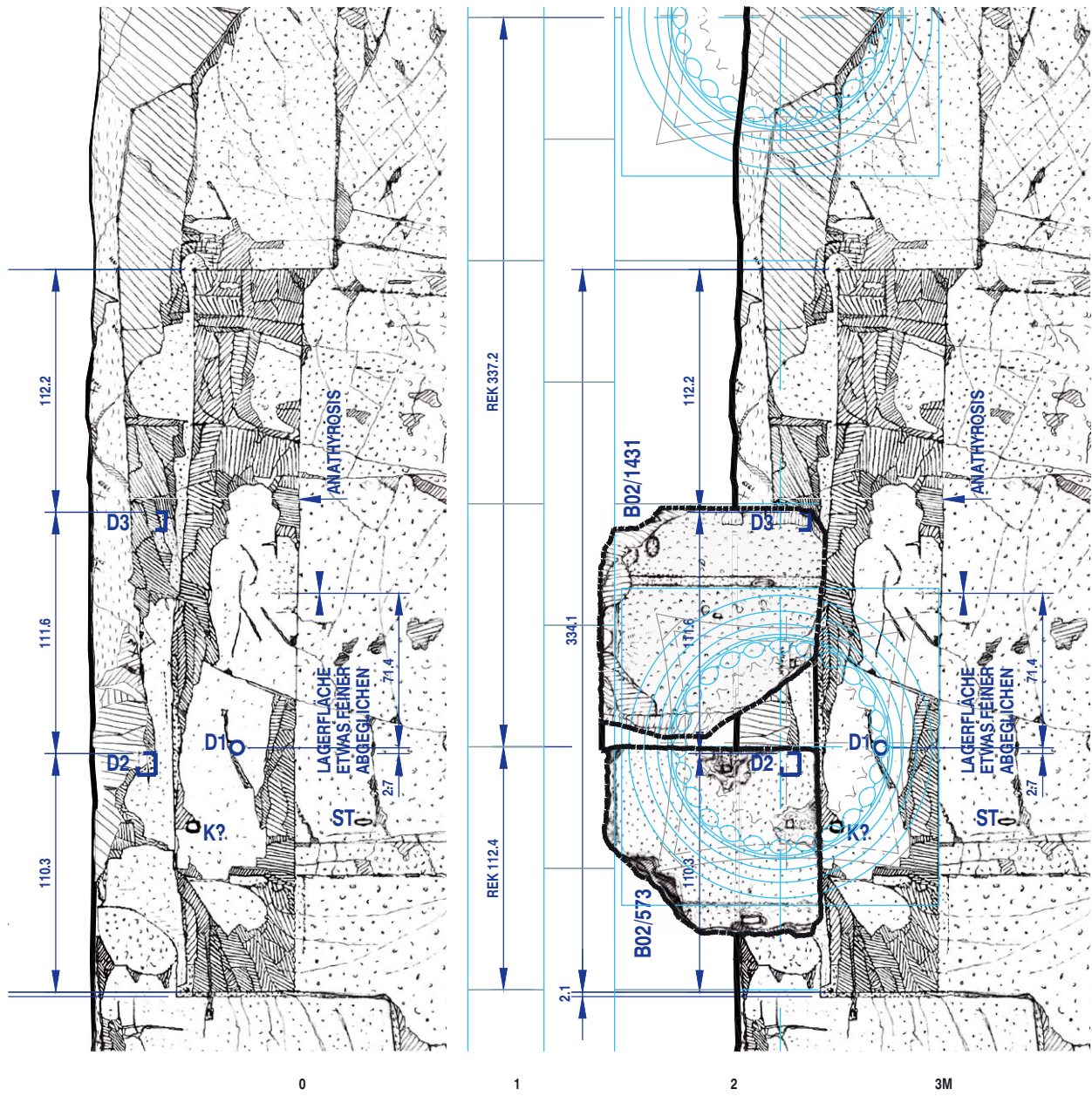

Felsbank nördlich der Südwestecke des Felskerns, Bestand und Rekonstruktion M = 1 : 20.

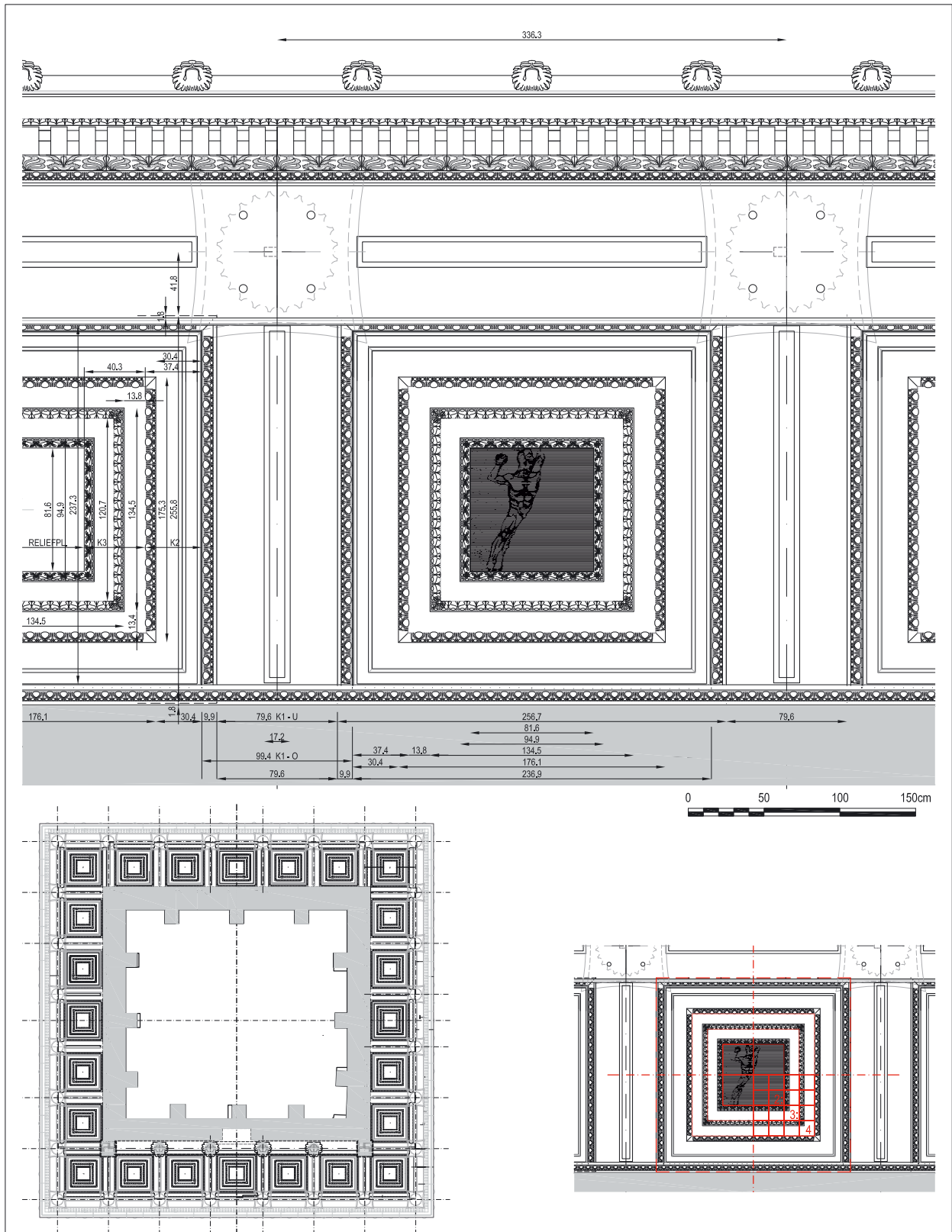

Deckenuntersicht Peristasis mit Kassetendecke M = 1 : 25, und Proportionsverhältnissen M = 1 : 50.

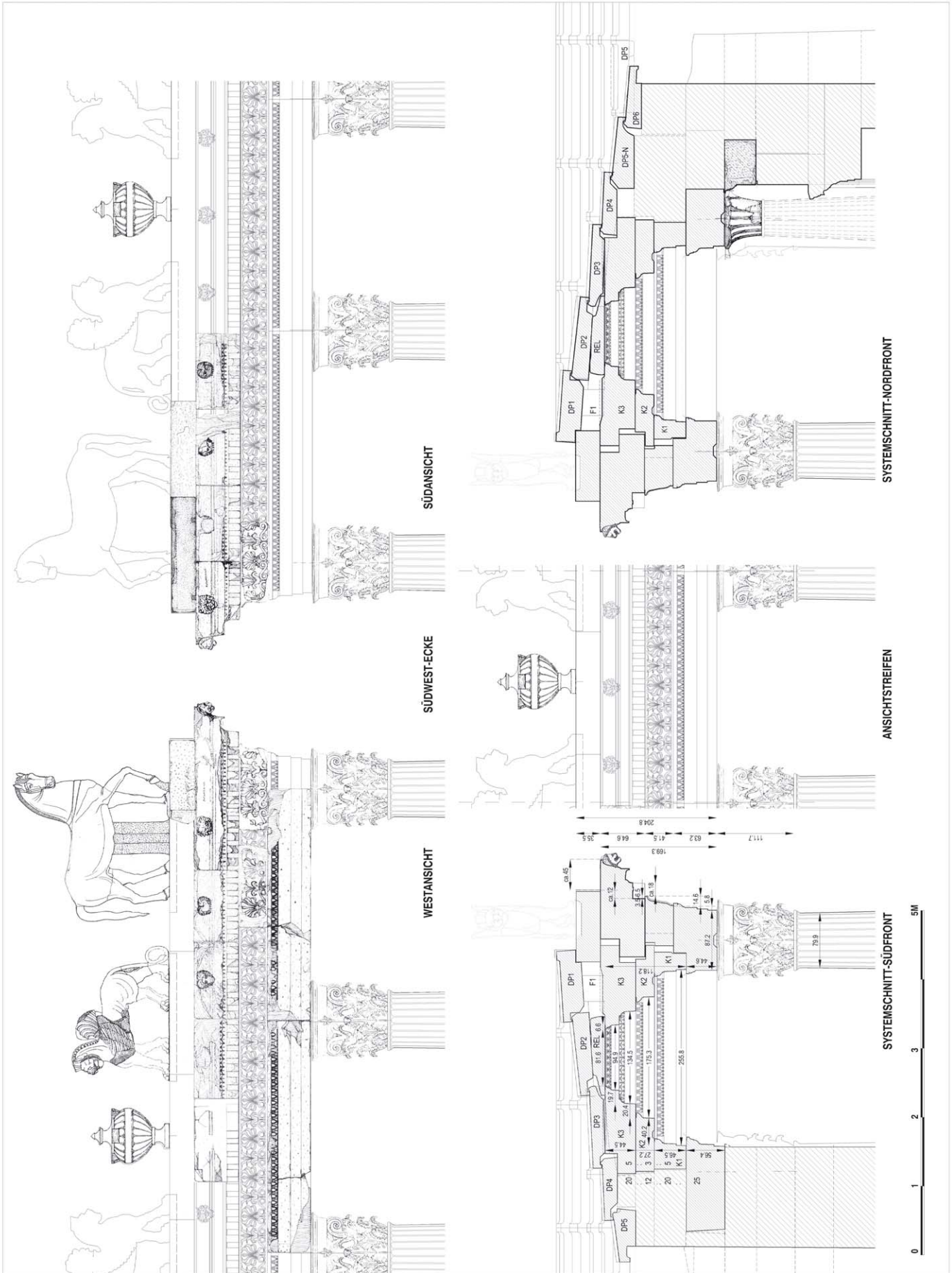

Peristasisgebälk und Kassettendecke, Schnitte und Ansichten M = 1 : 50.

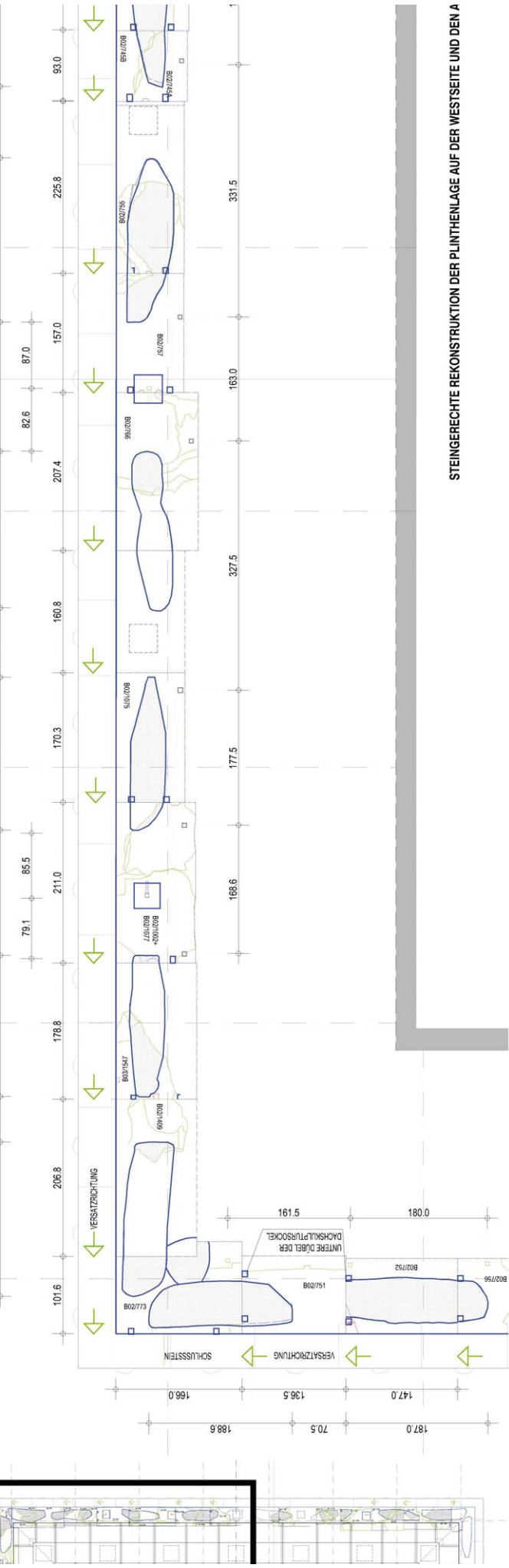

STINGERECHTE REKONSTRUKTION DER PLINTHENLAGE AUF DER WESTSEITE UND DEN A

M. 1 : 200

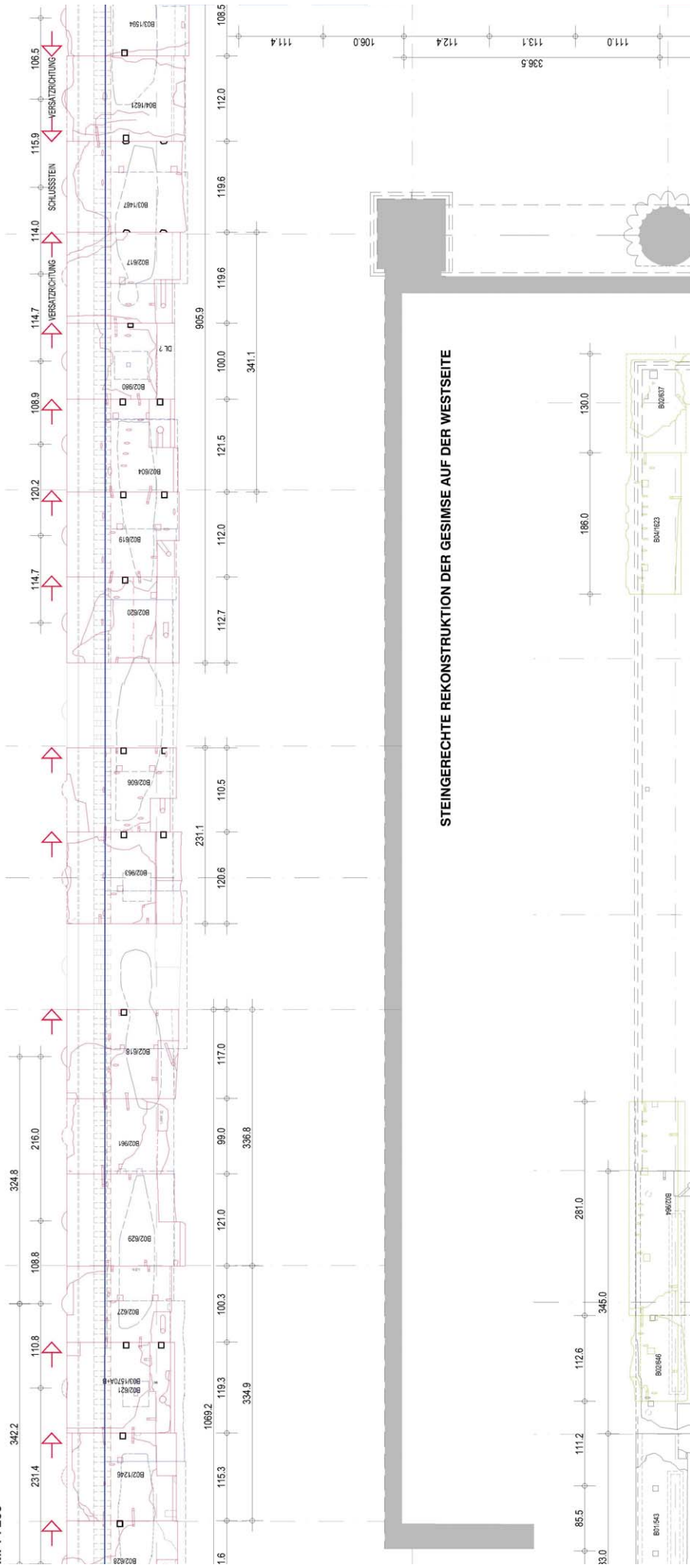

STINGERECHTE REKONSTRUKTION DER GESIMSE AUF DER WESTSEITE

TAFEL 142

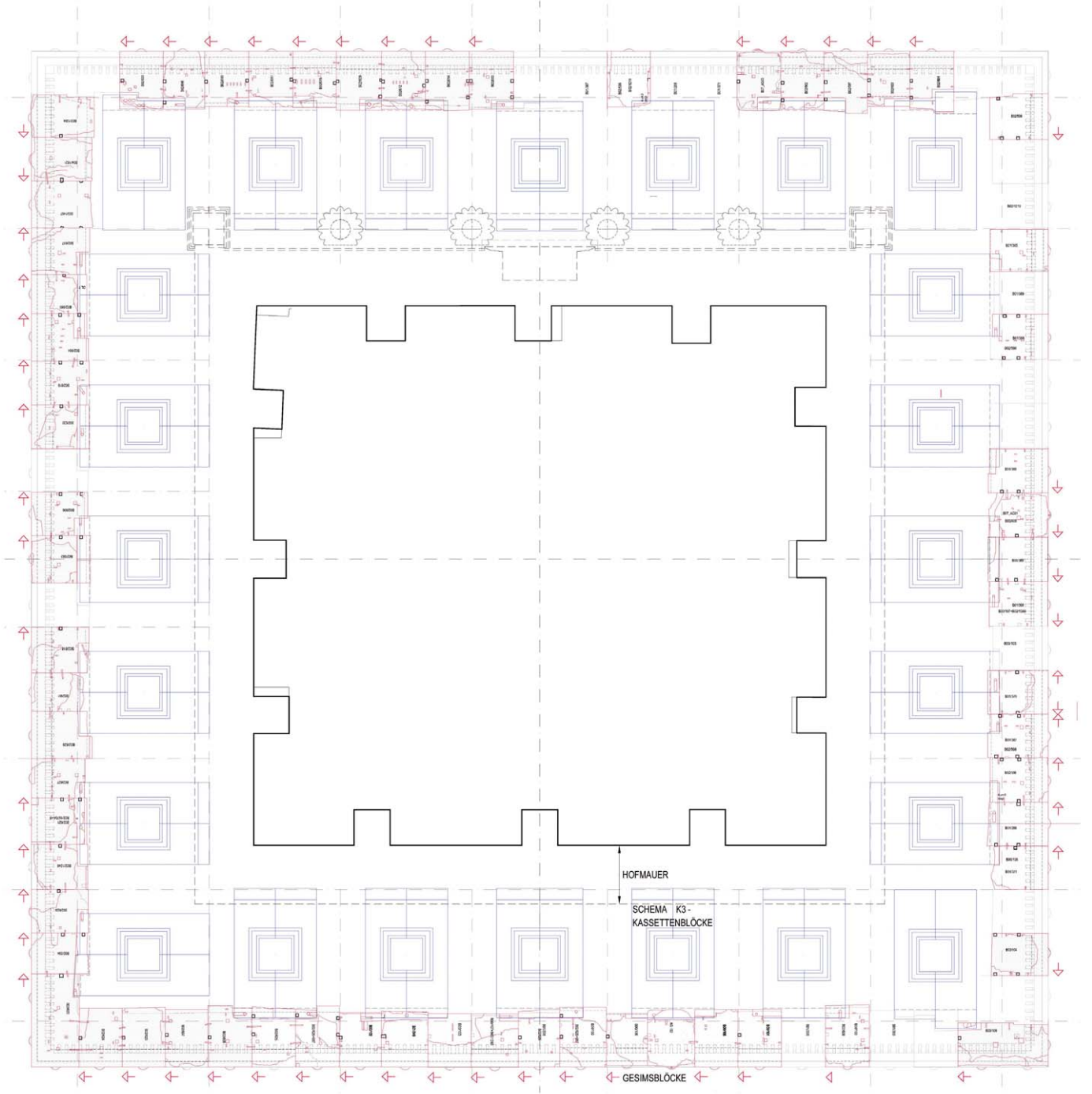

Gesimsblöcke der Peristasis und Lage der Kassettenblöcke K3 M = 1 : 100.

0 1 2 5m

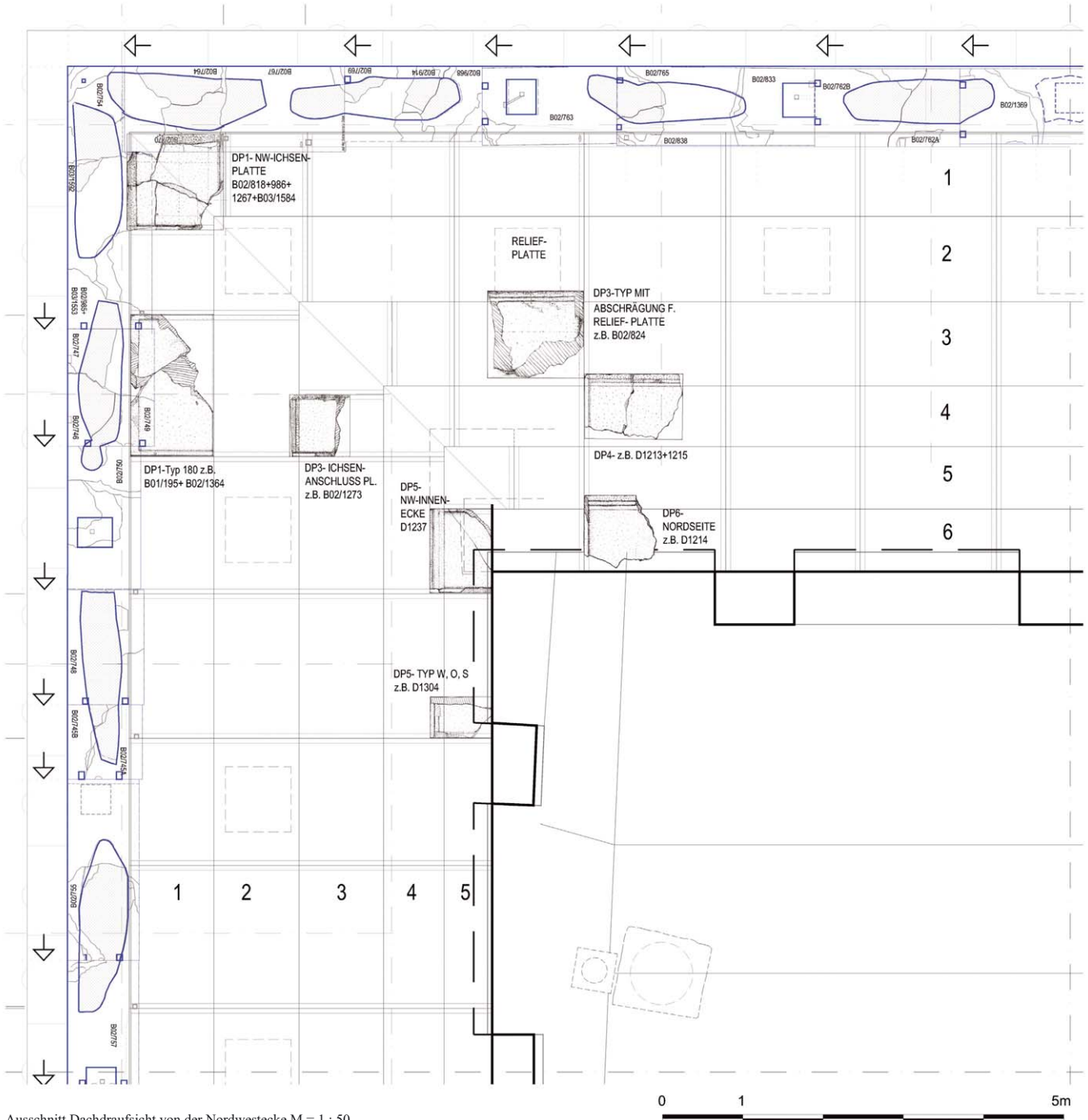

Ausschnitt Dachdraufsicht von der Nordwestecke M = 1 : 50.

TAFEL 144



1

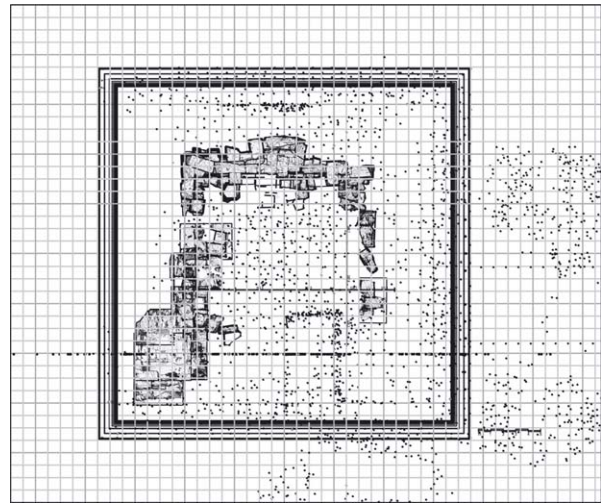

2

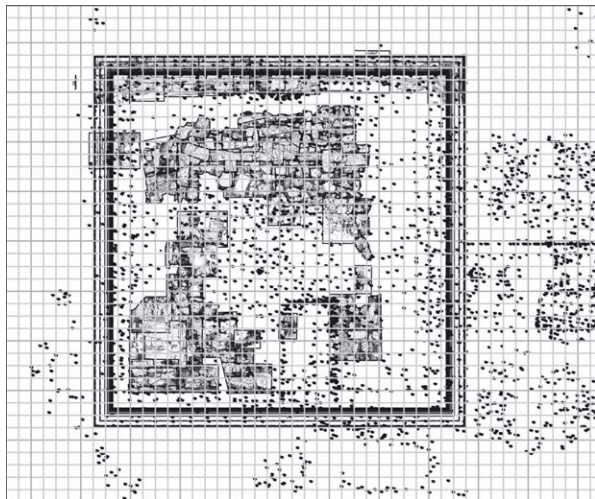

3

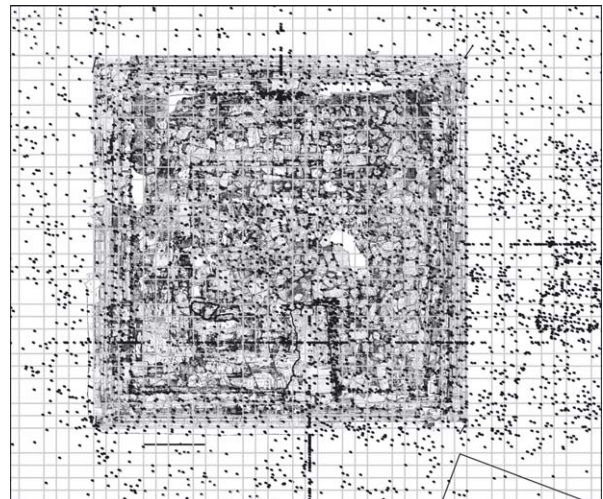

4

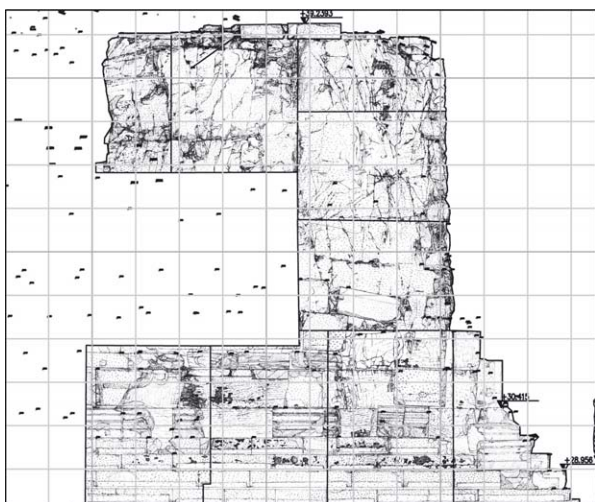

5

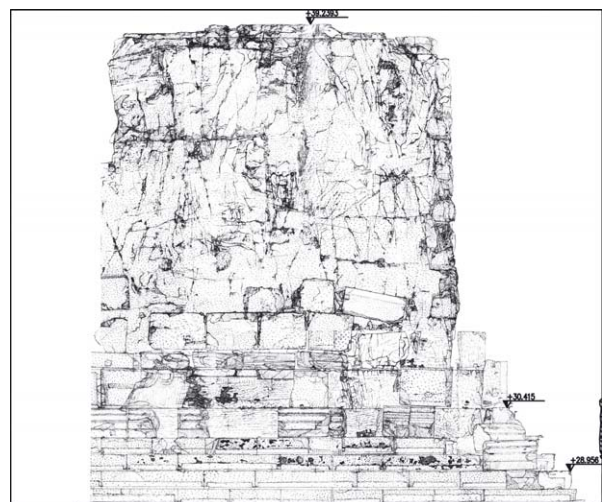

6

Methodik der Vermessung und Bauaufnahme;

1: Vermessungspunkte des Monuments und der Umgebung;

2-4: 2001-2004 Wachsen der Bauaufnahme mit darüber gelegtem Raster, Aufnahmemaßstab $M = 1 : 10$;

5-6: Aufnahme des Sütteils der W-Fassade, Aufnahmemaßstab $M = 1 : 10$.